

# TDM over Packet Network PseudoWire Emulation End-to-End

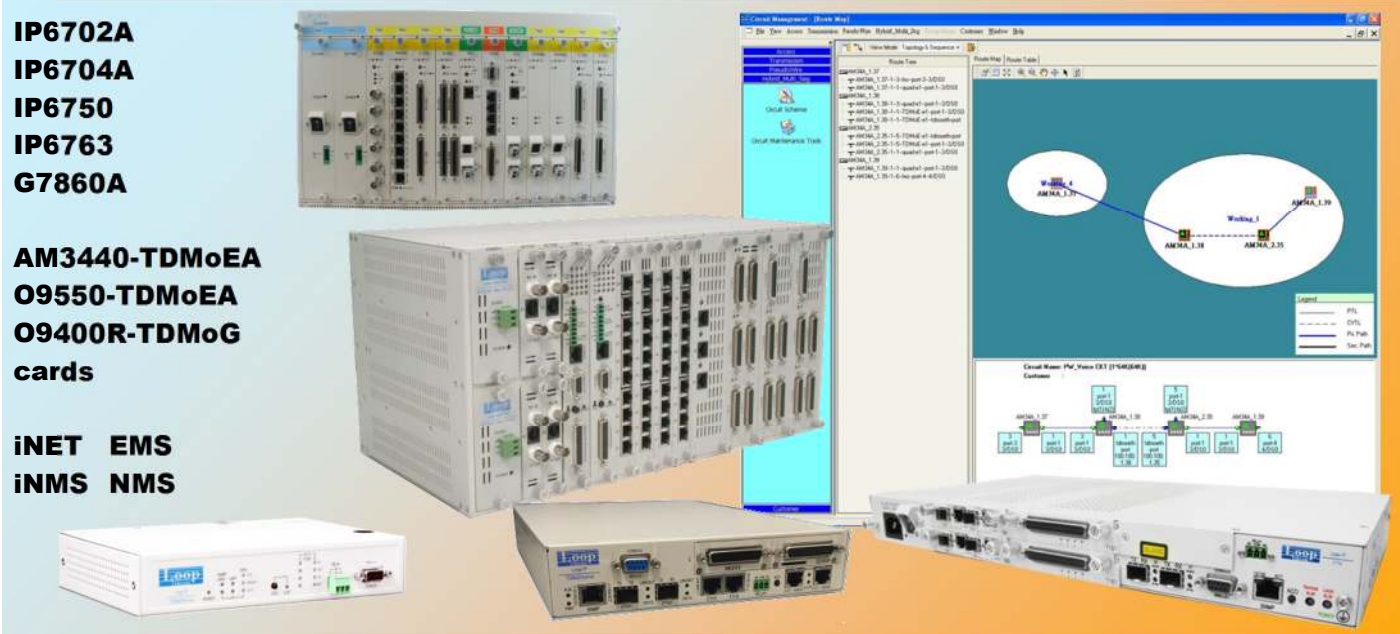

The TDM technology is clearly moving toward a packet IP or Ethernet core network solution. TDM traffic is sensitive to latency, requires high reliability. The existing installed base of TDM continues to be very large. There are literally thousands of installations for legacy and industrial applications supporting analog FXS, FXO, E&M, modems, radio, digital RTUs, utility teleprotection, radar, etc. Multiplexing such traffic over TDM links is still unavoidable. TDM PseudoWire is a direct solution allowing legacy and time sensitive installed applications to coexist inside IP/Ethernet. The PseudoWire Emulation End to End over switched packet Ethernet/IP/MPLS can transport a full range of services such E1, T1, E3, T3 TDM or ATM, or STM-x/OC-xx SDH/SONET together with IP or Ethernet traffic. This emulation transports not only the data but also the interface control of these links. It insures that the end point equipment is not missing the service of the interface. Loop equipment provides :

**From full conventional TDM/PDH Multi-services and SDH/SONET transport**

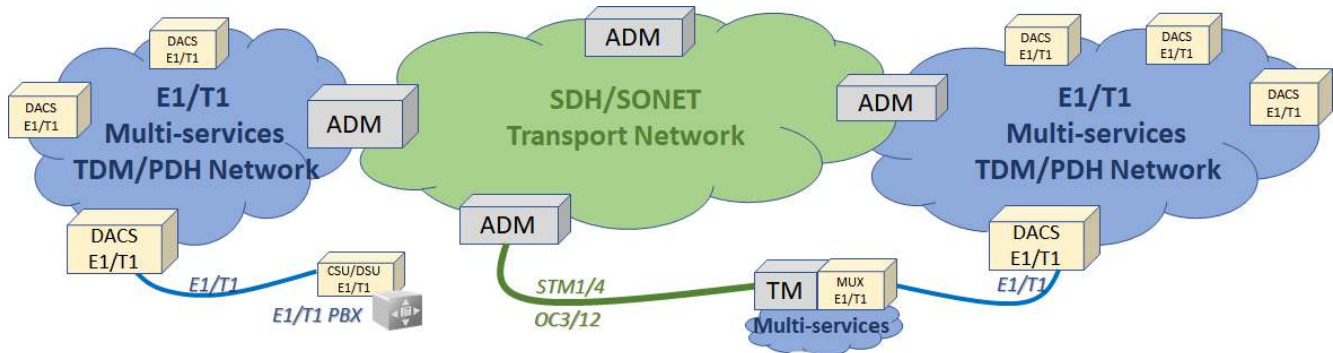

**... to partial or total migration over Packed Switched Networks: IP, Ethernet or MPLS**

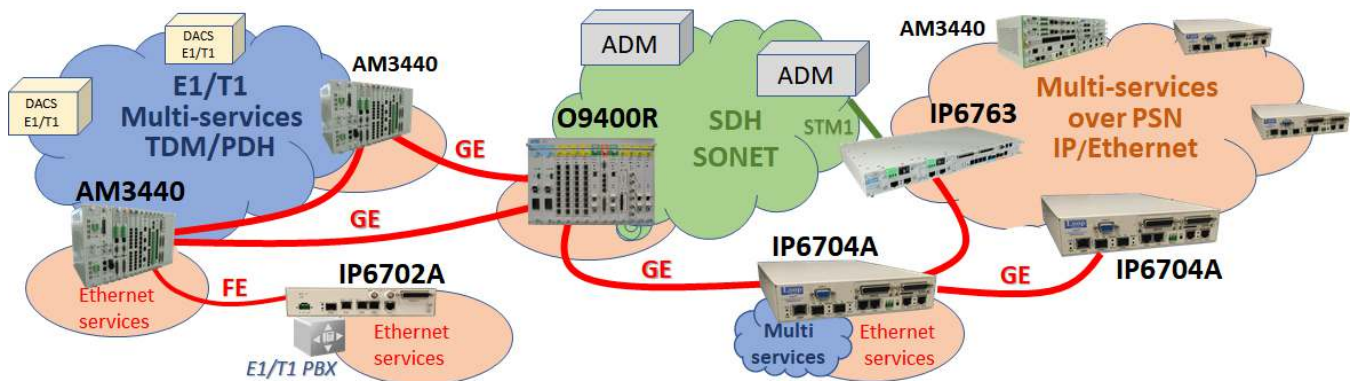

These PseudoWire equipment are designed for remotes small sites with few analog or legacy interfaces plus Ethernet services over fiber Ethernet as point to point or point to multipoint.



## IP6702A

1U, 1/2 19" device, option tray:  
Layer 2 switch with WAN/LAN:

- 1 x 100FX SFP
- 3 x 10/100BaseT
- VLAN, S-VLAN/C-VLAN

TDM tributaries :

- 1 x E1 120ohms/T1, RJ48
- Or E1 75ohms with 2 BNC
- Support E1/T1 G703, FE1/FT1 G704 n.64kbps framing and E1-CAS voice traffic

- 1 serial interfaces n 64kbps RS422 or X21\*

PseudoWire

- 16 simultaneous
- SAToP, CESoPSN, MEF-8\*



## IP6704A

1U, 1/2 19" device, option tray:  
Layer 2 switch with WAN/LAN:

- 2 x 100/1000 SFP
- 2 x 10/100/1000BaseT
- VLAN , Q-in-Q

TDM tributaries :

- 2 x E1/T1, with RJ48
- 2 factory modules for:
  - 1 or 4\* E1/T1, n.64kbps X21, RS232/V24, V35 or RS530\*, 1 C37.94 , 1 G703 64k CD
  - 4 E&M, 4 FXO, 4 FXS, 4 Magneto\* , Echo cancellation\*
- E1/T1 support G703, FE1 G704 n.64kbps framing and E1-CAS voice traffic

PseudoWire

- 16 simultaneous
- SAToP, CESoPSN, MEF-8\*
- ACR Automatic Clock Recovery.
- OAM, QoS
- Power supply: AC & DC or 2 DC

\* in implementation

*Loop Telecom has extensive expertise converting and transporting voice, analog signals, synch, asynch, legacy interfaces, teleprotection, dry contacts...and Ethernet over TDM or IP networks. We have developed a range of TDM over PSN solutions for our TDM/SDH/SONET customers who wish to interconnect over IP/Ethernet backbones or add new TDM sites using Ethernet backhaul where E1/T1 is no longer available.*

## The technology of TDM PseudoWire Emulation End To End over Packet Switched Networks (PSN: Ethernet, IP, MPLS)

TDM PseudoWire Emulation End to End (PW or PWE3) transports the full TDM service which includes:

- the TDM data Unframed or Framed including
- the bit streams for the CAS with Multi-frame, the CRC control and CCS for ISDN E1/T1, and
- the clock synchronization, which is very important for TDM networks and applications.

This is an **emulation of the full service End-to-End**. From the perspective of customer end equipment (CE), the PWE3 appears as unshared link with the designated service, like an E1 or T1 from a public network or and STM-1/OC12 from a SDH/SONET ADM.

The PWE3 provide a relatively straightforward mechanism to implement TDM/SDH/SONET services across packet-switched networks, and to achieve interoperability among arbitrary sets of equipment from multiple vendors.

### TDM Encapsulation/Emulation and constraint over PSN

IP/Ethernet networks are elastic and their stability of traffic depends on the switch or router nodes. The TDM links require high stability and low latency. In order to emulate correctly the PseudoWire over PSN we have to configure the emulation protocol to match the interface types, the size of the packets and the buffer size to limit jitter delay. Customers must make a compromise between small packet size with low latency requiring high bandwidth and larger packet size with more latency and but reduced required bandwidth. Loop provides tools and OAM to control these parameters.

### TDM PseudoWire emulation Protocols

**SAToP** (Structure Agnostic TDM over Packet) according to RFC 4553. This emulation is used to transport only unframed service or clear channel interfaces: E1, T1, E3, DS3 only.

An unframed data link, or any link transported as G.703, is sliced according to the synchronization but without consideration of content. This simple emulation protocol is mainly used for mobile transport.

**CESoPSN** (Circuit Emulation Services over Packet Switched Network) according to RFC 5086. This emulation is used to transport only framed service of n x 64kbps, E1, DS1, E3 and DS3 circuits only.

The customer must choose a multiple of E1 structured frames with a number of TS/DSOs in a CESoPSN frame. The latency is directly dependent on the size of this frame and the number of Time Slot (TS or DS0). This protocol is used by industry, Scada, teleprotection, for small independent circuits with few TS/DS0 dispatched to different application servers or RTU/NTUs.

## IP6704A A powerful Multi-services access and PseudoWire Gateway for substation

The Loop Telecom IP6704A is a powerful **Layer 2 switch** used in industrial customer premises to concentrate the Ethernet traffic through two Gigabit Ethernet links. The IP6704A supports different types of voice band signals and synchronous data over TDM PseudoWire Emulation. The IP6704A supports RSTP and MSTP protection.

### IP6704A multiple functions:

#### Multi-Services access multiplexer,

PCM voice band E1, T1, E&M, FXS, FXO, Magneto, Echo Cancellation Both A-law and u-Law PCM and synchronous data n x 64K/2Mbps, codirectional, C37.94... links.

**PseudoWire Gateway** that emulates these TDM services to PWE3 over Ethernet or IP networks.

**Layer 2 switch** with 4 FE/GE, 2 SFP and 2 copper used as WAN or LAN, Using VLAN, Q-in-Q, OoS and CoS with flow control of Ethernet traffic, it optimize the PWE3 over the WAN.

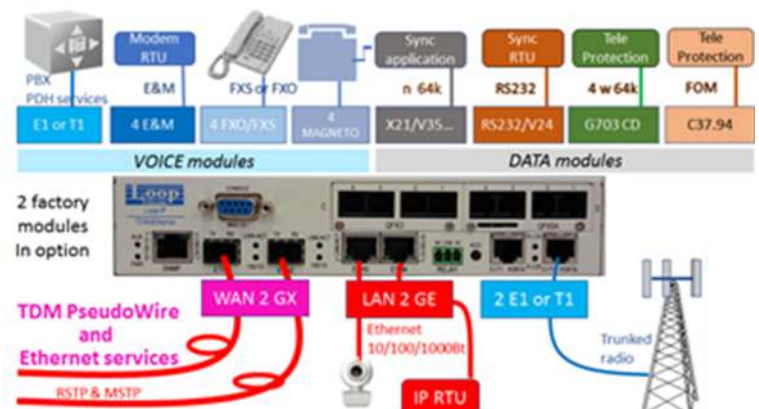

### Voice & Data transmission over Wireless



To simplify the deployment of conventional or legacy services together with Ethernet services the IP6702A, a compact Loop Telecom PseudoWire gateway, can easily carry an E1 for PBX or E1/T1 mux together with IP applications over point-to-point Wi-Fi using the Loop Telecom W8150 WiFi or W8320 400Mbps Ethernet over radio. The IP6702A supports E1/T1 Unframed or Framed G704 or voice T1/E1-CAS. The Layer 2 switch provides the bandwidth control to give PseudoWire the required priority versus the IP/Ethernet services. The remote radios and IP6702A can be managed from a central site with i-NET.

### Air Traffic Control

Air Traffic Control (ATC) is a significant user of radio voice communications between Aircraft and Air Traffic Control, with mandatory recording of all communications. Many AM3440s and O9550s are installed in ATC organizations around the world for a variety of TDM services, including radar transmission. The radios use E&M interfaces with additional Ethernet controls. This service can migrate easily to Ethernet by using the compact IP6704A PseudoWire gateway emulating up to 8 E&Ms. Daisy chaining can support more ports. The central sites use an AM3440 with TDMoEA and support up to 88 E&M radio ports and recording.

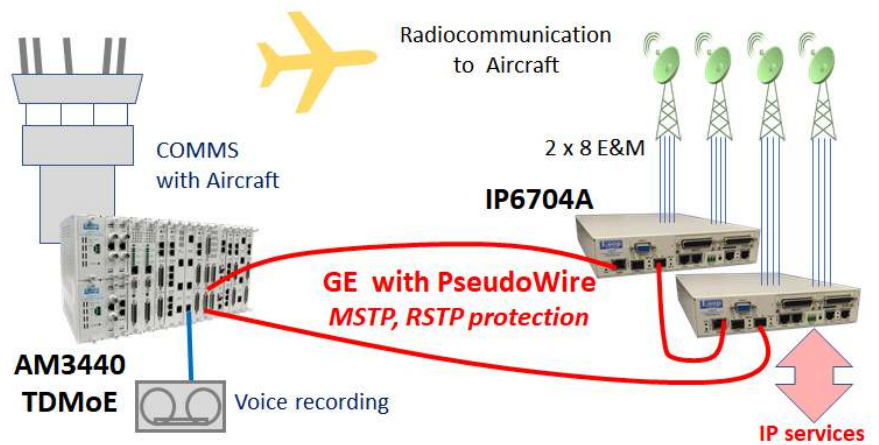

### Analog Voice, Conference and RTU communication for Railway

Loop Telecom supplies TDM DS0 multiplexing solutions to different railway companies around the world. Some of our railway customers want to migrate a part their application from main SDH/SONET transport to Ethernet fiber or from old copper connectivity to Ethernet backbone. IP6704A is a factory modular system, it is an economical solution to transport over Gigabit Ethernet fiber a part of dedicated Railway services without modification of end-to-end engineering which are tested and mandatory for Railway infrastructure.

The IP6704A nodes are secured by redundant power supplies, WAN fiber optic links with RSTP or MSTP ring protection and if necessary the equipment can be doubled per site for CPU and tributary redundancy.

E&M, FXO, FXS, magneto voice interfaces of the IP6704A carry voice traffic to PBXs or dedicate switchboards for railway.

The serial interfaces can support SCADA applications (RS232, G703 64K ) and the two T1/E1s can be used for trunked radio (PMR) along railway lines.

The internal L2 switch with VLAN, QoS... and the 2 - 100/1000BaseT LAN ports support the TDM PseudoWire services and the additional IP services such as IP-voice, IP-Video, access control...

An AM3440 with TDMoEA card can be used in the central node and NOC to concentrate up to 64 PseudoWires.

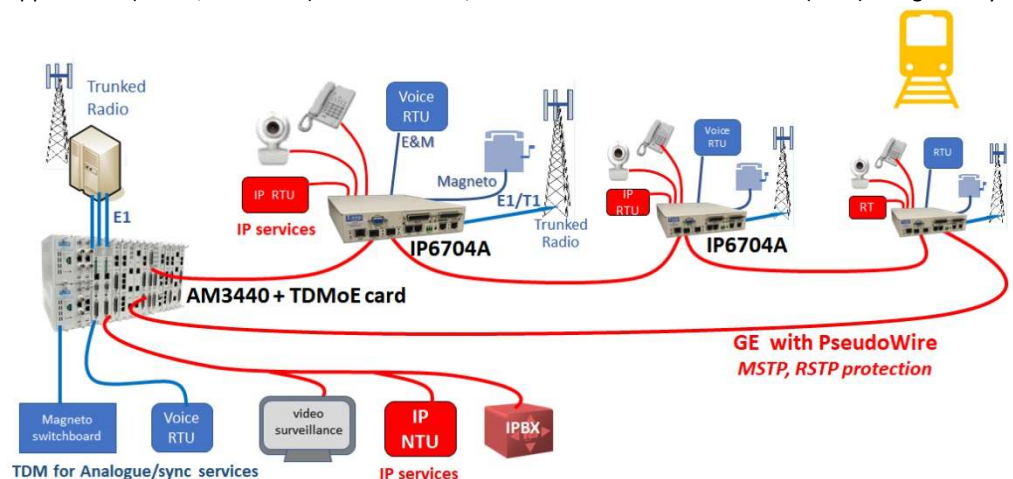

These concentration solutions are supporting TDM, SDH/SONET and TDM over Ethernet or IP networks.



## TDMoEA cards for AM3440 DSO DCS TDM and O9550-A, O9500R hybrid TDM & SDH

- This one slot card support 4 E1 or T1 backplane conversion to TDM over IP/Ethernet . Layer 2 switch with WAN/LAN
- 2 x Combo GE/GX SFP
  - 2 x 10/100/1000BaseT
  - VLAN , Q-in-Q , QoS PseudoWire
  - 64 PWE3 n.64kbp or 2Mbps
  - SAToP, CESoPSN, TDMoIP
  - ACR Automatic Clock Recov.



## IP6763A

- Layer 2 switch with
- 2 x GE Combo WAN
  - 4 x 10/100/1000BaseT LAN
  - VLAN , Q-in-Q , QoS
- TDM tributaries** factory opt.
- 32 x E1/T1: unframed G703, G704, E1-CAS, CRC, DS1/D4/ESF
  - 2 x 2 or 2+2 STM1/OC3
  - 1+1 STM4/OC12,
  - 252 VT11/VT12
- PseudoWires**
- VC4>VC4, VC4-4/c>VC4-4/c, VC12>E1 or >FE1, VC11>T1, E1>FE1 with TS grooming
  - 512 simultaneous
  - 32 with ACR supports
  - SAToP, CESoPSN, MEF-8, CEP for SDH/SONET
  - OAM, performance analysis



## O9400R-TDMoG

- Layer 2 switch with
- 2 x GE/GX Combo, 4 GE LAN
  - 4 VC4 back plane to SDH
- PseudoWires**
- VC4>VC4, VC4c>VC4c, VC12>E1, VC11>T1,
  - 512 simultaneous
  - 32 with ACR supports
  - SAToP, CESoPSN, MEF-8, CEP for SDH/SONET

The migration to the packet switching world will take a long time for many technical applications. Loop Telecom Multi-Services DACS support connection over traditional TDM/SDH/SONET and new IP/Ethernet links, backbone, fiber, wireless connecting new distant nodes for IP traffic plus Legacy, SCADA and low rate high sensitivity traffic.

### Protection of the of the TDM links with PseudoWire solutions:

**E1/T1 protection** The TDM multiplexer can provide a 1+1 protection of E1/T1 TDM copper/fiber by an E1/T1 PWE3 or between 2 E1/T1 PWE3. The conventional E1/T1 can be also protected by a TDMoEA over PSN network or inverse...

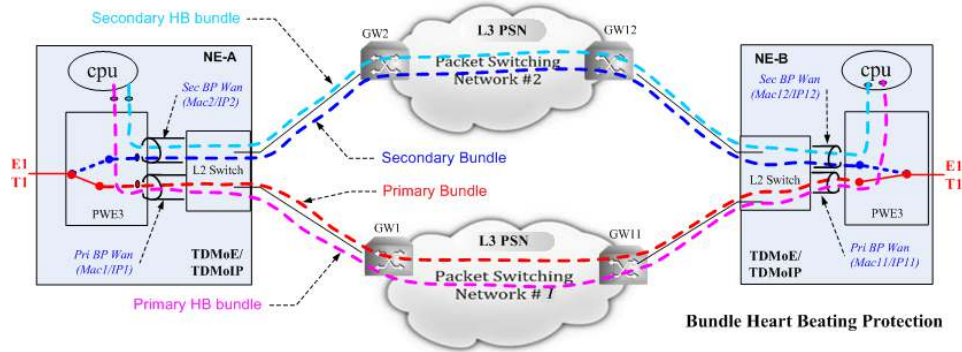

**Bundle Protection or Heart Beating Protection.** This 1:1 bundle protection is available in IP6763 and AM3440/O9550/O9500R-TDMoEA cards. Primary Bundle (PWE3) is using a Layer3 path with gateways and it is protected by Secondary Bundle with Layer3 protection path. In parallel to those traffic bundles, primary and secondary “Heart Beating” bundles are controlling availability of bundles and CPUs which will switch to secondary per selected rules on a number of missing periods in the primary.

**Ethernet WAN protection.** All Gigabit Ethernet WAN PW devices support RTSP, MSTP to protect at Layer2 the PWE3 circuits over the networks. The MSTP protocol with VLAN can be used to optimize the protection of the PW traffic versus other lower priority Ethernet traffic.

### WAN for TDM PW and growing Ethernet traffics with QoS and CoS

Many factors, including the migration of TDM to Ethernet, is resulting in increasing local Ethernet traffic. To accommodate this, the TDMoEA card has 4 - GE copper or fiber interfaces usable as WAN or LAN. Other models have 2 - GE combo WAN and 4 - GE LAN with internal 10GE L2 switch. All support link aggregation for high bandwidth WAN traffic. Bandwidth necessary for TDM PWE3 traffic is preserved using VLANs, Q-in-Q for other LAN traffics, rate limiting per Ethernet port n x 64kbps to n x 10Mbps and switching QoS based on PCT for Ethernet frames with 4 or 8 queues (\*1). Additional beneficial features are IP DSCP, TOS scheduling with SP or WRR algorithms. Thus the Ethernet transport capability is maximized while insuring the priority necessary for TDM time sensitive traffic.

### OAM and Diagnostic test of TDM interfaces and PW

Different models of PseudoWire equipment provide different test features. Please refer to the various brochures and manuals.

We support the local/distant loop test and 24-hour performance in 15-minute intervals for E1/T1, SDH/SONET interfaces. The system provides internal information, direct tests such as ARP, Ping and Trace Route and per PseudoWire/Bundle the Round-trip Delay analysis with record of mini/maxi/average. These products provide Pseudowire Information of Packet Creation Time (ms), Jitter-Tolerance Delay (ms) and with an external software

### Optimization of the PseudoWire concentration

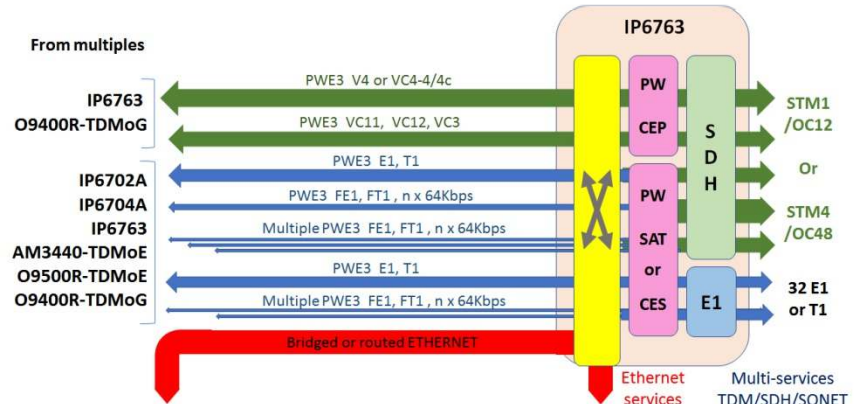

## Migration of Multi-Services applications application to IP/Ethernet transport

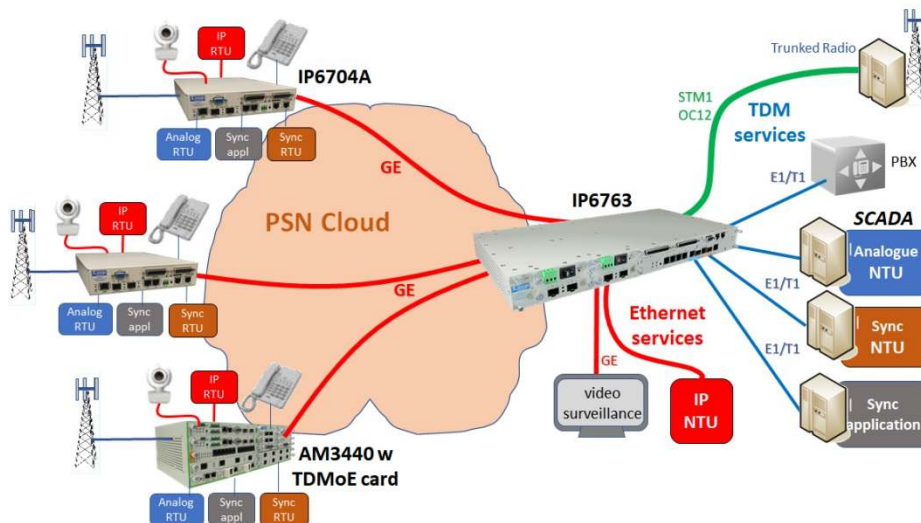

Loop Telecom PseudoWire Gateway family can replace, for Multi-Services, the existing TDM/PDH or SDH/SONET transport networks by PseudoWire interconnection over a Packet Switching Network IP or Ethernet. The remote access equipment is replaced by small gateway IP6702As or IP6704As or for large density of interfaces, an AM3440 with the TDMoEA card. In the above illustrations we use the IP6763 universal gateway. The IP6763 converts PseudoWire from remote sites (E1, FE1, T1, FT1, voice, SCADA, Sync/Async serial traffic, etc) to physical E1 or VC12/VC11 within STM1/OC3 interfaces for SDH/SONET networks. The IP6763 is doing PseudoWire grooming of IP6704A and AM3440 interfaces in the same E1, T1, VCxx and avoids adding a TDM/PDH or a SDH/SONET ADM. The IP6763 is a concentration site which supports up to 512 PWE3 and synchronizes up to 32 remote PseudoWire gateways with ACR mode. The IP6763 is used to support a larger number of remote sites (32E1/T1 and 4 - STM1/OC3 or 1 - STM4/OC12 interfaces) or can be used for simple Ethernet backhaul. The IP6763 combines the Ethernet traffic concentration and Layer 2 switching with VLAN and Q-in-Q from remote gateways with full support of the QoS required for PWE3 transport.

## Power transport/distribution, Oil and Gas plant or Chemical Industrial complex... Interconnection of existing TDM/SDH/SONET networks with Gigabit backbone, Addition of remote node over Ethernet Backhaul.

In many large industrial infrastructures, the transport networks for TDM/PDH and SDH/SONET are installed and are working correctly with reasonable OPEX cost for applications requiring stability, low latency, voice, serial data, Ethernet, etc. The new network installations are built with Ethernet backbones but without TDM/SDH/SONET capabilities required in the original networks. The PseudoWire emulation gateways are the right solution to interconnect TDM/SDH/SONET networks by implementing the new GE/10GE/... backbone. Each conventional network will provide their synchronization and the addition of the TDM/PDH or SDH/SONET networks will be monitored by the same management system, the Loop iNMS. In case customers wish to add a new TDM DACS as AM3440 or a new SDH/SONET Terminal Multiplexer we will use PseudoWire Emulation of E1 or STM1/4 over Ethernet backbone and the local node will synchronize the remote node in Automatic Recovery Clock (ACR) mode over the backbone or Ethernet link. Point to point 1+1 protection is preserved via either the PWE3 or with Ethernet WAN protection.

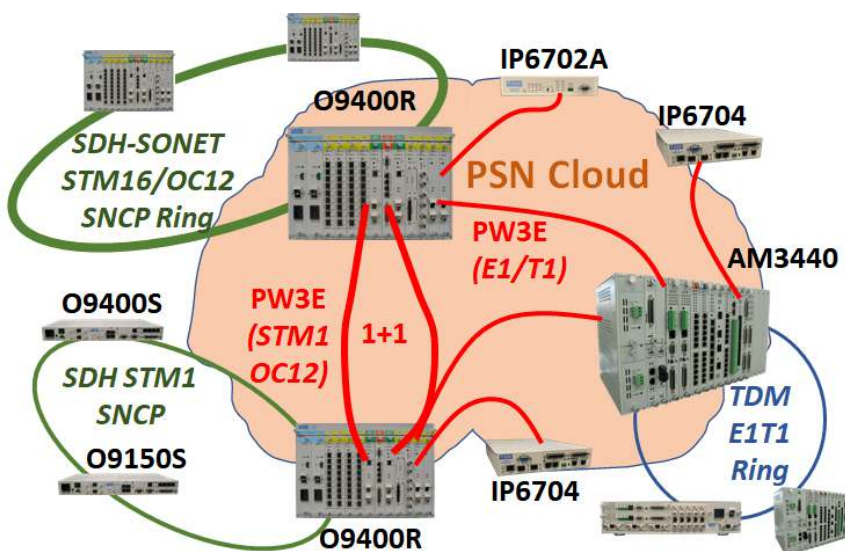

## 10G PTN with MPLS-TP or CE protocols solutions

In case of multiple node deployments, it can be easily achieved by deploying Loop Telecom PTN MPLS-TP solutions based on G7860 or O9400R-PTN or O9500R-PTN equipment. These products combine TDM/PDH, SDH/SONET and GE/10GE with MPLS-TP or Carrier Ethernet protocol.

Please contact Loop Telecom.

Loop produces a new range of devices used for Mobile backhaul and for industrial application with E1/T1 and with deployment of multiple Ethernet flows .



## IP6750

Service Aggregation and Access Device, PTN Carrier Ethernet

- 2 x GE Combo WAN
- 4 modules for
- 4 E1/T1 with DB37
- 2 GE Combo SFP and RJ45

### PseudoWires

- E1, T1, FE1, FT1 with TS grooming
- 64 simultaneous PWE3
- 32 with ACR or DCR for remote synchronization
- Adaptive Clock Recovery
- Differential Clock Recovery
- SAToP, CESoPSN, MEF-8 (CESoEth)

### Layer 2 switch

- 5GB non blocking switching
- SyncE GE ports,
- IEEE1588v2 slave, boundary transparent clock, Stratum 3
- TOD and 1PPS interfaces
- VLAN , Q-in-Q, QoS
- OAM 802.1ag, Y.1731, 802.3ah
- G.8031, G8032\* protection
- RSTP, MSTP\*



## G7860A

PTN Concentrator, Backbone, Service Aggregation Device, Carrier Ethernet / MPLS-TP

- 6 GE/10GE SFP+, 4 GE SFP
- 2 modules for
- 8 GE SFP or 8 FE/GE RJ45
- 4 STM1 or 1 STM4 SFP
- 32 E1/T1 with SCS1

### PseudoWires

- E1, T1, FE1, FT1, VCxx, VC-4c
- ACR or DCR
- PW/LSP, SAToP, CESoPSN, MEF-8 (CESoEth), CEP
- VPLS, VPWS, H-VPLS for Ethernet services

### Layer 2 switch

- 85GB non blocking switch
- SyncE GE/10GE ports,
- IEEE1588v2 slave, boundary transparent clock, Stratum 3
- TOD and 1PPS interfaces
- VLAN , Q-in-Q, QoS
- OAM 802.1ag, Y.1731, 802.3ah
- G.8031, G8032\* protection
- RSTP, MSTP\*

Loop Telecom produces a new range of Packet Transport Network equipment that support SyncE GE and 10GE interfaces with PTP1588 and MPLS-TP or Carrier Ethernet 2 transport protocol. These products support the transport of E1/T1, TDM Multi-Services, SDH/SONET and Ethernet services with high level of reliability and maintain TDM clock distribution and latency. The iNMS system supports the installation and administration of mixed services to optimize CAPEX and OPEX for migration. (Migration & evolution, no forklifting required!)

## E1/T1 and Ethernet extension over fiber or cloud

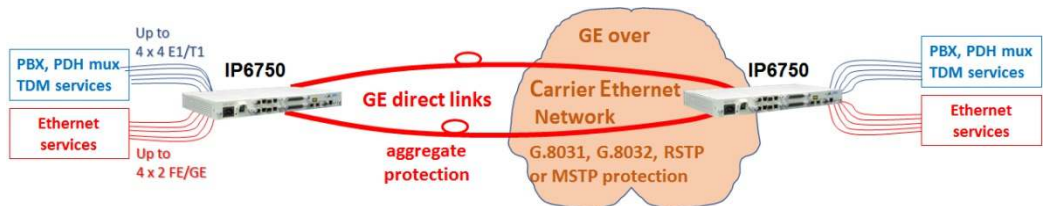

The IP6750 is a powerful switch with two optical GE WANs to carry Ethernet services and E1/T1 TDM circuits over PseudoWire. This can be used as a single Ethernet switch with TDM extension over simple dark fibers supporting link aggregation protection. It IP6750 can also be used over a structured cloud as a Carrier Ethernet network with G.8031 ELPS, G.8032 ERPS, RSTP or MSTP protection.

Using SyncE Gigabit Ethernet and PTP 1588, the IP6750 provides frequency and time synchronization to remote devices and following remotes over 6 chained hops. This synchronization is needed by TDM terminals and secure applications.

Use as Point to Point, or Daisy chain. This powerful Layer 2 switch supports VLAN, Q-in-Q, QoS and OAM to deploy sensitive applications in power, industry, telecom back haul, military...

## Ethernet backhaul for 2G/3/LTE BTS deployment

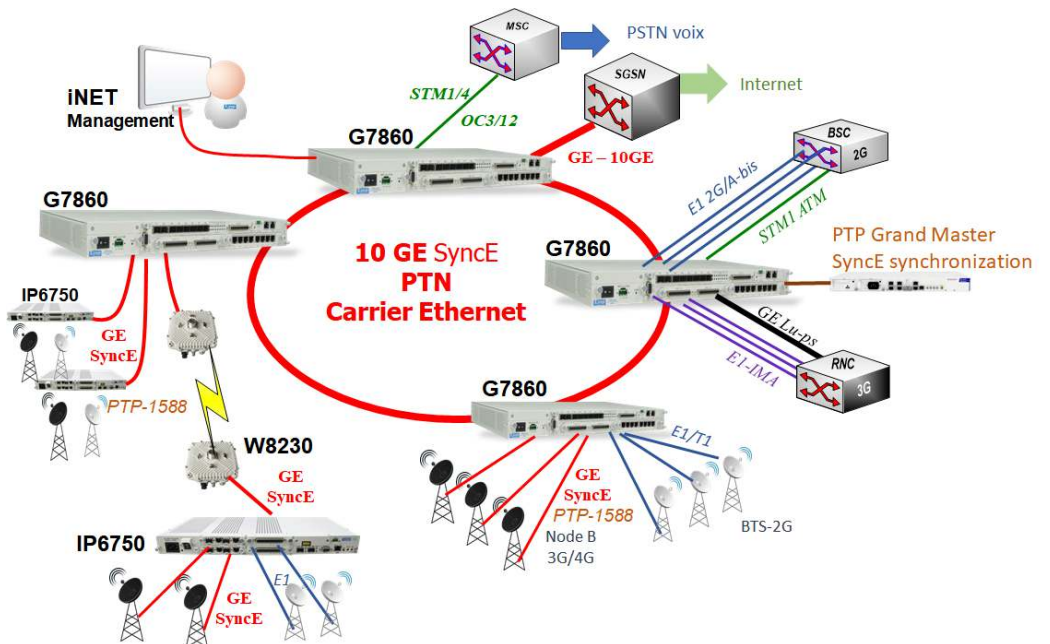

Ethernet backhaul based on IP6750s can be deployed for T1/E1-TDM for 2G Base Transceiver Stations, T1/E1-Inverse Multiplexing over ATM for 3G Node-B, and Gigabit Ethernet for 3.xG and LTE node B. The IP6750 supports SyncE WAN and PTP 1588 for frequency and phase synchronization for BTS and Node B. The IP6750 with WAN or Combo tributary ports can distribute connections to other units and provide synchronization for up to 7 IP6750s or other units in a daisy chain. Where fiber is not available, The IP6750 can be used over Loop (or 3rd party) Ethernet radios. Loop radios operate up to 400Mbps and 20km. Radio extensions can also carry GE SyncE. The BTS/Node-B is also carried over the combined network.

For large infrastructures Loop has the G7860A PTN device. The G7860A supports CE or MPLS-TP transport protocol to concentrate up to 22 GE SFPs over four 10GE ports of MPLS-TP or CE networks. (BSC, RNC and PSTN or RNC, SGSN and Cloud). The G7860A supports the transport of Ethernet VPLS/VPWS, PseudoWire emulation over LSP of E1, T1 and the VC12, VC4, VC4-c or VC-4c circuits over LSP. These features allow administration of BTS sites by LSP number management. Smaller networks are effectively monitored through iNET. Larger networks are typically managed by the Loop iNMS system which supports automatic commissioning and documentation of end-to-end LSP and PseudoWires circuits.

**iNET** Loop-iNET, based on scalable and modularized architecture, is an intelligent network management software for Element Management Layer (EML) and Network Management Layer (NML) based on Telecommunications Management Network (TMN) model. It provides a GUI (graphical user interface) for the management of a communications network containing Loop Telecom products and 3rd-parties NE .

The Loop-iNET management system is a Web based application using MS Windows server platforms and MySQL RDBMS database server.

Loop-iNET features a hot standby server option for redundancy with automatic switchover for high availability (HA). The system access security is based on users with privilege access that are customized for a combination of operational functions and managed NEs, with user access logs, single or multiple GUI users. Multi-hierarchical subnet structure allows users to provide multi-level network topology displays. This SNMP based management system supports functions including configuration commands, alarms, and statistics gathering.

iNET can support up to 100,000 Network Elements (NEs) of TDM, Ethernet and PseudoWire Loop Telecom devices and generic 3rd-party NEs. The robust and reliable design provides a flexible and scalable solution for network expansions.

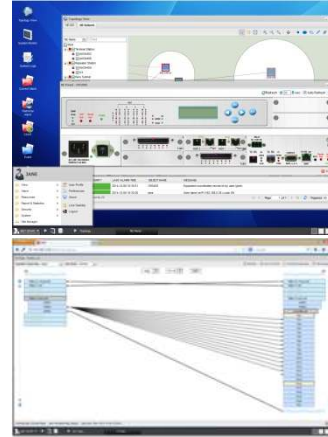

**iNET-LCT**

This light Window software is a Local Craft Interfaces.

This basic version of the iNET NMS is permitting to set-up node per node locally or over the network and gives the vision of all setting and cross-connects of the device.

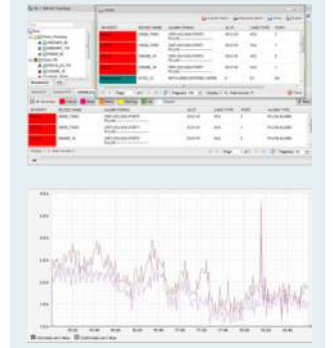

**iNMS-NMS** Loop-iNMS (Integrated/Intelligent Network Management System) is a set of software programs supporting the Loop equipment compliant to TMN. This system manages the devices for the Transport Network (SDH), Access Network (PDH), Ethernet with PseudoWire-3E and PTN over MPLS-TP.

This is a GUI based system, with End-to-End commissioning with several services for small to very large infrastructures. iNMS supports a NBI to access a head end NMS.

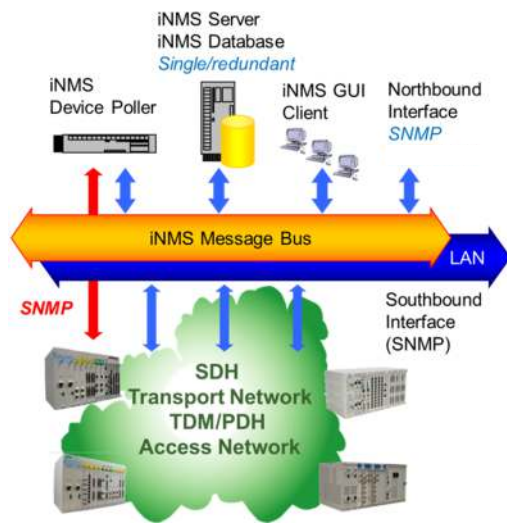

- Full SNMP supports functions including commands, alarms, and statistics gathering
- Viewing and printing of all node statistics, alarm reports, configurable report design
- Enriched topology management with GIS geographic maps, zoom and drag-and-drop
- Views of optical cable connection, cross-connection, panel view, and resource trees
- Clock Distribution Map
- System Redundancy and Protection
- Efficient performance monitoring in real-time and history for PM, NE and circuits
- Alarm management with notification via e-mail, GSM message (SMS), with filtering
- Root Cause Analysis accurately diagnoses faults on NEs and managed circuits by status and severity levels
- System Access Security and many options to customize your requirement.

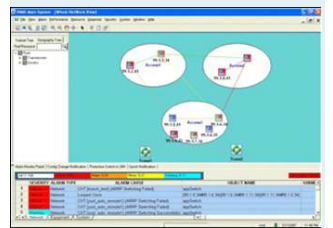
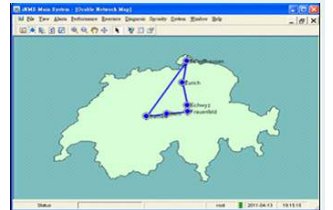

The iNMS system :

- The software runs Linux with
- Database Server: Oracle 10g, 11g, 12g\*
- User-friendly GUI on MS Windows platform. Up to 50 GUI clients simultaneously are logged.
- iNMS support several thousand SNMP Loop nodes and 3rd-Party NE .

All servers, database, pollers can build with redundant with High Disaster Recovery option. iNMS provides to administrator:

- High Level NMS
- GUI of device and Network view
- End-to-end service management with automatic commissioning of nodes

**For PseudoWire iNMS provides the management and commissioning of**

- PseudoWire Circuits commissioning PWOIP, PWOEth and PWO MPLS
- Hybrid Multi-Segments Circuit : Access TDM + PWE3 + TDM
- For IP67xx PseudoWire gateway PWOIP, PWOEth with bundle protection
- For G7860 PTN MPLS-TP support PWOEth and PWO MPLS with LSP and LSP protection and the automatic-commissioning of nodes and LSP.
- OAM for End to End circuit over IP or Ethernet network or LSP.

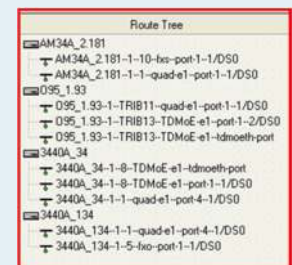
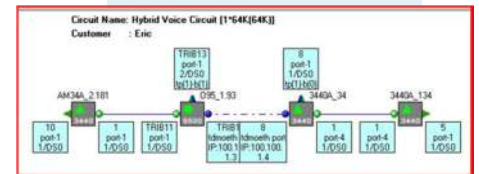

# TDM PseudoWire Emulation End to End over Packet Service Networks

Models	IP6702A	IP6704A	IP6750	IP6763	IP6700-E3	TDMoEA card for AM3440-A/B/C		TDMoG card for O9400R
<b>System</b>	<b>TDM PseudoWire Emulation End-to-End (PW-E3) system stand alone</b>					<b>PW-E3 card for PDH/TDM DACS</b>		<b>PW-E3 card for SDH/SONET ADM</b>
		1U, ½ 19"	1U, ½ 19"	1U 19"	1U, ½ 19"	Modular ETSI 5U, 2.5U or 3U		Modular 5U ETSI
	1 SNMP CPU AC or DC or AC&DC	1 SNMP CPU AC&DC or 2 DC	1 SNMP CPU AC or 2 DC	1 SNMP CPU AC or 2 DC	1 SNMP CPU AC or DC	2 redundant SNMP CPUs 2 DC red.	AC or 2 DC	2 redundant SNMP CPUs 2 AC or 2 DC red.
<b>PseudoWire (PWE3) Emulation protocol</b>	SAT unframed CESoPSN framed MEF 8 (CESoEth)*	SAT unframed CESoPSN framed MEF 8 (CESoEth)*	SAT unframed CESoPSN framed MEF 8 (CESoEth)	SAT unframed CESoPSN framed CEP SDH, MEF 8	SAT unframed	SAT unframed CESoPSN framed MEF 8 (CESoEth)		SAT unframed CESoPSN framed CEP SDH, MEF 8
<b>Number of PWE3</b>	16	16	64	512	1	64		512
<b>PVD compensation</b>	Up 256ms	Up 256ms	Up 256ms	Up 128ms	45 & 60ms	Up 340ms		Up 128ms
<b>Bundle protection</b>	-	-	-	Yes L3	-	Yes L3		-
<b>Emulation of services in PWE3</b>	E1, FE1, T1 or serial	E1, FE1, T1, FT1 or serial or voice	E1, FE1, T1, FT1	VC4, VC4-4c, VC3, VC11, VC12, E1, T1 VC12 to FE1/FT1	VC3	E1, FE1, T1, FT1 or serial or voice		VC4, VC4-4c, VC3, VC12, E1, T1, E3, DS3 VC12 to FE1/FT1
<b>Clock recovery master</b>	ACR for 4 remotes	ACR for 4 remotes	ACR & DCR for 64 remotes	ACR for 32 remotes	-	ACR for 16 remotes		ACR for 32 remotes
<b>WAN or LAN interfaces</b>	1 FX SFP 3 x FE	2 FX/GX SFP 2 x FE/GE	WAN 2 GX SFP LAN with module	WAN 2 Combo GE LAN 3 FE/GE	WAN 1 FE or FX LAN 1 FE	WAN 2 Combo GE LAN 3 FE/GE		WAN 2 Combo GE LAN 4 FE/GE
<b>over PSN</b>	IP or Ethernet	IP or Ethernet	Carrier Ethernet, MPLS-TP*, SyncE & PTP1588v2	IP or Ethernet	IP or Ethernet	IP or Ethernet		IP or Ethernet
<b>Ethernet protection</b>	-	RSTP, MSTP	RSTP, MSTP, G.8032	RSTP, MSTP	-	RSTP, MSTP		RSTP, MSTP
<b>Tributaries interfaces</b>	2 fixed	2 fixed + 2 factory modules	4 mini slots	32 E1/T1, 2 mod. SDH/SONET	1 fixed			
<b>SDH/SONET</b>	-	-	-	4 STM1 or 1 STM4 4 OC3 or 1 OC12 MSP 1+1		The main multiplexers AM3440-A/B/C and O9550-A/C support		The main O9400R supports 4 STM1 or 1 STM4 MSP 1+1
<b>Cross-connect</b>	-	-	From TDM to PW	From TDM to PW		Full non blocking DACS DS0		Full SDH VCxx
<b>Tributary PDH E1,T1,E3,T3</b>	1 E1/T1 Frame/Unframed	2 to 10* E1/T1 Frame/Unframed	0 to 16 E1/T1 Frame/Unframed	0 to 32 E1/T1 Frame/Unframed	1 E3 or 1 DS3 Unframed	E1/T1 Framed/CAS/Unframed		up to 388 E1/T1, 18 E3/DS3 Frame/Unframed
<b>DTE n x 64K X21/V35/IEA530/RS232</b>	1 RS422/V11	0 to 2 X21,RS232, V35,IEA530*	-	-	-	X21, V35, V36, RS232, RS485, RS422		-
<b>E&amp;M, Magneto, Conference</b>	-	E&M, Magneto*	-	-	-	E&M, Magneto, Conference		-
<b>Voice FXO, FXS, Echo Cancellation</b>	-	0 to 8 FXO or FXS, Echo Cancel*.	-	-	-	FXS or FXO, echo cancellation		-
<b>G703 64k, C37.94</b>	-	0 to 2 G703, C37.94	-	-	-	G703 64k,C37.94,Teleprotection		-
<b>Environment</b>	Fanless	Fanless	Fanless	Fan	Fanless	Chassis Fanless		Chassis Fan or Fanless
<b>Size (WxHxD)</b>	210 x 41,5 x 140 mm optional Tray	213 x 41 x 290 mm optional Tray	438 x 44 x 300 mm	438 x 44 x 225 mm	210 x 41,5 x 140 mm optional Tray			
<b>Temperature</b>	-10 to +55°C	-10 to +55°C	-10 to +60°C	-10 to +55°C	-10 to +55°C			
<b>Compliances std</b>	FCC Part 15 Subpart B, Class A - CE - Safety IEC60950-1							
<b>Other compliances</b>		IEC61850-3*	IEC61850-3*			IEC61850-3, EN50121-4		IEC61850-3, EN50121-4*
<b>Management</b>	Telnet/SSHv2 Craft	Telnet/SSHv2 Craft	Telnet/SSHv2 Craft	Telnet/SSH Craft	Telnet Craft	Telnet/SSHv2 Craft		Telnet/SSHv2 Craft
<b>Local Port or over TS</b>	RS232, Eth	RS232, Eth	RS232, Eth	RS232, Eth	RS232	RS232, Eth and TS		RS232, Eth and TS and DCC
<b>SNMP</b>	v1, v3	v1, v3	v1, v3	v1, v3	v1	v1, v3	v1, v3	v1, v3
<b>LCT Interface</b>						Node administration Windows GUI		
<b>iNET (EMS)</b>	Windows GUI , Graphic cross-connect, vision of programed circuit					Windows GUI , Graphic cross-connect, vision of programed circuit		
<b>iNMS (NMS)</b>	Support Transport, Access, PW3R circuits, automatic node commissioning, synchronization					Support Transport, Access, PW3R circuits, automatic node commissioning, synchronization		
* in development or qualification								



**Data Comm for Business, Inc.**  
**2949 CR 1000 E**  
**Dewey, IL 61840**  
**Voice 8004DCBNET (800.432.2638)**  
**Fax 217.897.1331**  
**Info [www.dcbnet.com/contact.html](http://www.dcbnet.com/contact.html)**  
**Web [www.dcbnet.com](http://www.dcbnet.com)**