

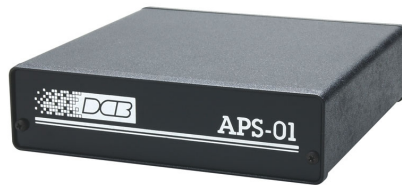

SPS-01



APS-01



NPS-01

FEATURES

- Remote control AC power to other equipment
- Provides status output
- Works with any appropriate control command source
- Simple RJ45 connection for LAN, network, or control leads
- APS-01 is data lead controlled
- NPS-01 is controlled via TCP/IP Ethernet
- SPS-01 is serial RS232 controlled
- 10 AMP rating
- Rack mount option available
- Use to reboot remote equipment
- NPS-01 includes a watchdog timer

DESCRIPTION

The **APS-01**, **NPS-01** and **SPS-01** remote power modules control AC power to any remote equipment. They differ by the controlling method.

When The **APS-01** is used with the DCB Access Switch, it allows the equipment to be turned on, off, and power cycled from any remote PC or terminal. The DCB Access Switch provides options for power cycle delay time, sequencing of multiple power modules, normally on or off conditions, and control of any number of AC devices from one to 152. The APS-01 can be used as a power control switch when used with the DCB IP-6600 router. The APS-01 can also be used with the SMD SCADA Multidrop Multiplexers.

The **NPS-01** controls power to any remote equipment by using commands received through a TCP/IP ethernet interface. The source of the commands may be a Telnet connection, web browser, or SNMP management workstation. AC powered equipment can be turned on, off or power cycled from any remote PC, or other device using a web browser or telnet client.

Power status is reported back to the browser or telnet client. The NPS-01 also features a watch dog type ping monitor. When enabled, if the controlled device does not respond to a ping, the NPS-01 will cycle power to it's connected device.

The **SPS-01** controls power using ASCII commands received through an RS232 interface. No configuration is required, however the dwell timer for a power cycle may be set. The SPS-01 echoes commands and provides status back to the controlling device so the remote operator knows if power to the controlled device is on or off.



NPS-01 Rear View

APS-01, NPS-01, SPS-01 Remote Power Switches

SPECIFICATIONS

General

One AC port with fail-safe and status feedback
Power units on, off, or power cycle equipment

Control Input

APS-01

Control Port Connector: RJ-48S (RJ-45)
Control Input: Pin 2 input +5 to +12 VDC turns AC on, -5 to -12 VDC turns AC off
Device Present Status: Ties pin 1 and pin 8 together to indicate APS present Status (output from APS-01):
Output Status: Pin 3 ties to pin 1 when device is on and powered

NPS-01

10/100 Ethernet port
Configure and control via web browser, Telnet, or SNMP

SPS-01

Control Port Connector: RJ-48S (RJ-45)
RS232 serial port, 9600 bps, 8 data bits, no parity, 1 stop bit
Control using ASCII commands

AC Output

One port 120 VAC, 10 amp continuous
230 VAC export model available

Indicators (rear panel)

AC Power on
Load Power on

APS-01 Operation (When APS-01 is used with DCB Access Switch)

Access Switch Setup Commands
Port ID
Access Switch Operational Commands
Port_id ON
Port_id OFF
Port_id (Status)
Port_id Cycle

Physical/Electrical

Power requirements: 120/ VAC, 10 amps or less, depending upon attached equipment (Export 230 VAC model available)
Dimensions: 1.5" X 5.75" X 5.5"
Rack mount option available; (3 units mount in 1.75" of rack space)

Environmental

- Operating Temp: -40 to +70 C
- Storage Temperature: -50 to +75 C
- Humidity: <95% Non-condensing

Ordering:

Specify APS-01, NPS-01 or SPS-01
Specify 230VAC European if required

Manuals Available On-line:

Download the user manual from our web site at <http://www.dcbnet.com>

APPLICATION

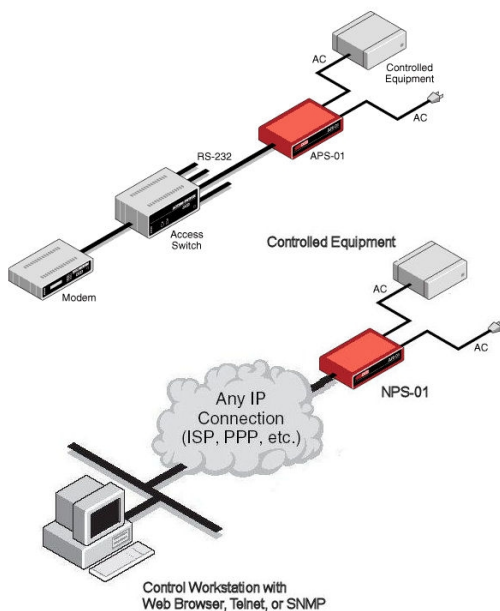

Data Comm for Business, Inc.
2949 CR 1000 E
Dewey, IL 61840

Voice 8004DCBNET
(800.432.2638)

Fax 217.897.1331

Email www.dcbnet.com/contact.html

Web <http://www.dcbnet.com>