TABLE OF CONTENTS

SECTION 1 - DESCRIPTION.....2

SECTION 2 - SPECIFICATIONS.....3

SECTION 3 - INSTALLATION.....4

SECTION 4 - OPERATION.....5

SECTION 5 – CONTROLS AND INDICATORS.....6

SECTION 6 – RS-232 INTERFACE DESCRIPTION.....7

SECTION 7 - WARRANTY.....9

Data Comm for Business, Inc.
2949 County Road 1000 East
Dewey, IL 611840
(217) 897-6600
www.dcbnet.com

November 28, 2022
Firmware Version: 1.0

1. DESCRIPTION

The Serial Power Switch (SPS-01) controls AC power to any remote equipment by using ASCII commands received through an RS-232 interface. The SPS-01 allows AC powered equipment to be turned on, off, or power cycled from any remote PC, terminal, or other RS-232 connection. No configuration is required, however the dwell time for a power cycle may be set.

The SPS-01 also echos commands and provides status back to the controlling device so the remote operator knows if power to the controlled device is on or off. If the connection to the controlling terminal is lost, the SPS-01 maintains the current status of the switch.

The SPS-01 may be used in conjunction with DCB remote access Switches, multiplexers, or other devices with an RS-232 output port.

2. SPECIFICATIONS

2.1 Ports

One AC Power port
One RS-232 control port fixed at 9600 bps

2.2 Indicators

AC Power on
Load Power on

2.3 Environmental

Operation: -40 to +70° C, non condensing humidity
Storage: -40 to +85° C, non condensing humidity

2.4 Physical / Electrical

1.5" x 5.75" x 5.5"
120 or 240VAC (model dependent), 10 Amps max.
Fuse: 250V 10A, Type ABC 10

3. INSTALLATION

3.1 Unpacking

The following is included with each SPS-01

- SPS-01 power control module
- Cable for attaching SPS-01 to PC 9-pin port
- Manual
- Information regarding warranty, maintenance contracts and repair

3.2 Location

Place the SPS-01 in a clear area where you can reach the rear panel to connect the cables. The SPS-01 must be connected to a properly grounded AC outlet

3.3 Connection to controlling devices

See the RS-232 interface description in Section 6 for the RJ-45 cable pinout. The controlling device may be any device capable of issuing commands at 9600 bps via an RS-232 interface; a PC, remote serial port, modem, etc. See section 6 for wiring details or purchase adapter hoods from DCB.

4. OPERATION

4.1 Connection

To connect a PC to the control port use the cable and adapter provided. Run terminal emulation software on the PC and set the software for 9600 bps, 8 data bits, no parity, one stop bit and no flow control.

4.2 Commands

The SPS-01 responds to commands received via the RS-232 control port. Commands may be verbose or quiet. Verbose commands are ASCII commands using either upper or lower case letters terminated by the <Enter> key. Quiet commands are single character commands. After acting on each command, a response is returned.

<u>Verbose</u>	<u>Quiet</u>	<u>Description</u>
on	1	power on
off	0	power off
flip	f	invert state
cycle	c	invert, pause, invert state
show	s	show current state
quiet	v	toggle quiet/verbose command mode
write	w	save current settings
help	?	display help

Issue the commands to the power switch from the attached controlling device. Commands are echoed, immediately acted upon, and a response given that indicates the state of the switch after the command operation. When using verbose commands, only enough characters to fully identify the command are required.

The cycle command takes a single argument, NNN, number of seconds (0 to 255) to pause during the cycle. Once entered, this value is saved until changed with another cycle NNN command or a power cycle. The quiet cycle command "c" does not allow the parameter and uses the last saved value. To save this value through power cycles by using the write command.

The write command will save the cycle time, verbose/quiet mode, and power state to non-volatile memory. If power is cycled to the SPS-01, the last saved settings will be restored.

5. CONTROLS AND INDICATORS

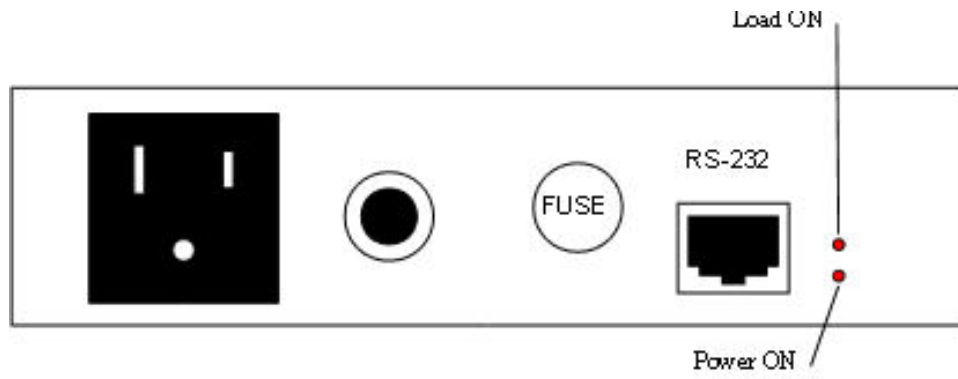

SPS-01 Rear View

6. RS-232 INTERFACE DESCRIPTION

6.1 Connector Pin Reference

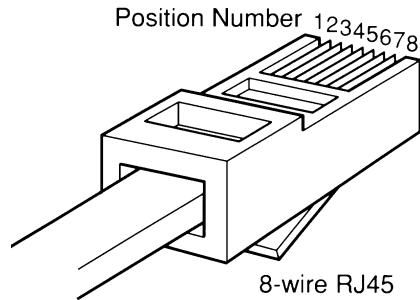

RJ-45 Plug Positions

6.2 RS-232 Port (RJ-45)

<u>Pin</u>	<u>Signal</u>	<u>In/Out</u>
1	+V 5 volts	OUT
2	+V 5 volts	OUT
3	Not Used	
4	Signal Ground	-----
5	Receive Data	OUT
6	Transmit Data	IN
7	Not Used	
8	Not Used	

6.3 Cables

This is a straight through line cord and a hood adapter. DCB adapter part numbers are shown in parenthesis.

6.3.1 Control Port to Terminal (9802016)

SPS-01 RJ-45	Terminal DB-25P
1	6
2	8
3	20
4	7
5	3
6	2
7	5
8	4

6.3.2 Control Port to Modem (9802018)

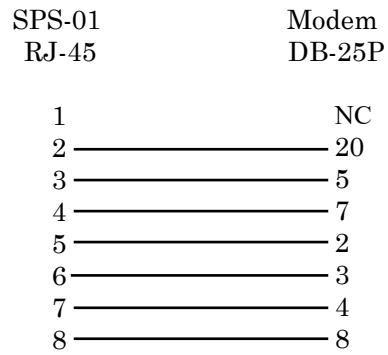

6.3.3 Control Port to a PC Com Port (9802013 or 9802014)

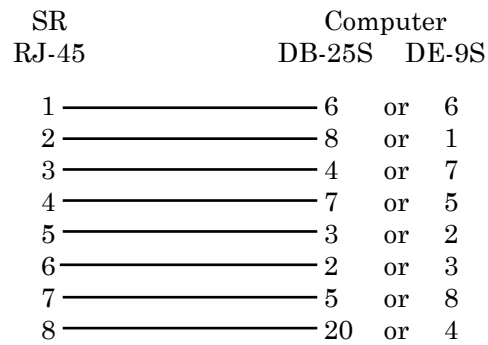

7. WARRANTY

All DCB products are warranted to be free of defects in materials and workmanship for one year. Data Comm for Business, Inc. will repair or replace any equipment proven to be defective within the warranty period. All warranty work is F.O.B. Dewey, IL. This warranty is exclusive of abuse, misuse, accidental damage, acts of God or consequential damages, etc. DCB liability shall not exceed the original purchase price.

All equipment returned for repair must be accompanied by a Returned Material Authorization (RMA) number. To receive an RMA number, call (217) 897-6600 between the hours of 8 AM and 5 PM central time or complete the on-line RMA form at http://www.dcbnet.com/rma_request.html. Equipment must be shipped prepaid to DCB and will be returned at DCB's expense.

Ship returned items to:

Data Comm for Business
RMA#
2949 County Road 1000E
Dewey, IL 61840

Data Comm for Business, Inc.
2949 CR 1000 E
Dewey, IL 61840

Tel (217) 897-6600
Fax (217) 897-1331
Email support@dcbnet.com