

SR 4 Multiplexer

TABLE OF CONTENTS

SECTION 1 - DESCRIPTION.....	2
SECTION 2 - SPECIFICATIONS	4
SECTION 3 - INSTALLATION.....	7
SECTION 4 - CONTROLS AND INDICATORS.....	15
SECTION 5 - NETWORK MANAGEMENT PORT	18
SECTION 6 - INTERFACE SIGNALS AND CABLING.....	26
SECTION 7 - TROUBLESHOOTING.....	32
SECTION 8 - WARRANTY.....	34

Data Comm for Business, Inc.
PO Box 6329
Champaign, IL 61826-6329
(217) 897-6600
www.dcbnet.com

October 4, 2006
Firmware Version: 5.6

1. DESCRIPTION

The DCB SR series statistical multiplexers are used in pairs to allow asynchronous RS-232 devices to communicate through a single composite (network) data link. The network may be synchronous or asynchronous, using leased lines, dial-up modems, ISDN, radio links, or digital data service. Asynchronous terminal devices may be terminals, printers, plotters, computer ports, etc.

Each data port is configured individually at speeds up to 57,600 bps.

Network speeds may be as high as 115.2 Kbps asynchronous or 128 Kbps synchronous.

The SR multiplexers also control the data flow to and from each RS-232 device. These individually configured flow control parameters may either be software controlled (Xon/Xoff) or hardware controlled through the RS-232D interface.

The multiplexer is configured using a network management port or port one of any unit using an asynchronous terminal or PC with terminal emulation software. Multiplexer configurations are kept in non-volatile memory.

Some features of the SR 4 include:

- Automatic full time or on-demand dial-up operation.
- Test message generation to any local or remote port.
- "Copy" commands to allow host site trainer to assist remote trainee.
- Monitor functions allow network management port user to monitor transmit or receive of any data port.
- Capture command to allow network management port user to control a remote data port.
- Many test features allow diagnostics of the system and communications link.
- Error correction on all network data.
- Power supplies available for 120 or 240VAC and 12, 24, 48, or 125VDC

Options:

- Built-in 56 or 64Kbps DSU/CSU.
- Built-in wireless modem.
- Built-in 56K Dial-Up Modem
- Rack mount options available.

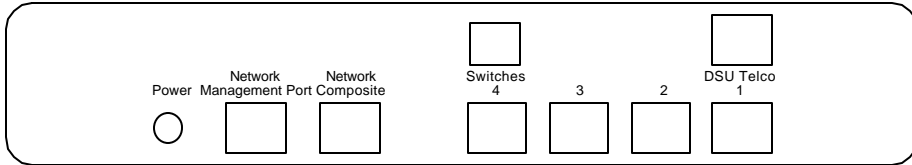
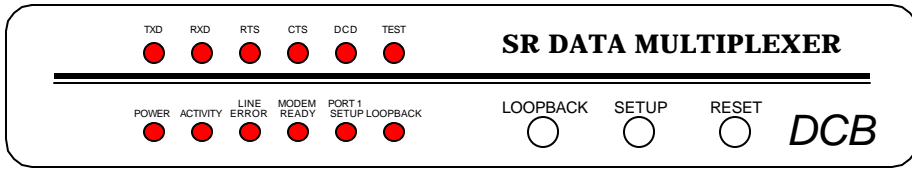

SR 4 Multiplexer shown with optional built-in DSU/CSU

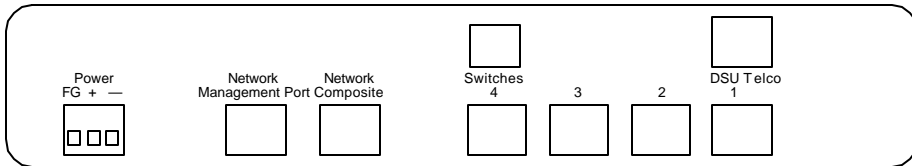

SR 4 Multiplexer shown with DC power option

2. SPECIFICATIONS

2.1 Product

2.1.1 Data Ports

Port Speeds

Asynchronous only

300, 1200, 2400, 4800, 9600, 19,200, 38.4 or 57.6 Kbps

Port Rate Selection

Selected per port through network management port control with an asynchronous terminal.

Data Format

10 bits/character, 1 start, 1 stop, 8 data (including parity)

Interface

CCITT V.24, RS-232D, implemented in RJ-45, 8 position connectors. (RS-561 standard physical pin-out used on RJ-45 connectors)

Port Flow Control

Input (SR control of data input to each port)

Software: Xon/Xoff

Hardware: Clear to Send

Output (Attached device control of output from each SR port)

Software: Xon/Xoff

Hardware: Busy High or Busy Low

Port Flow Control Selection

Selected per port through the network management port with an asynchronous terminal.

Buffering

32K dynamically allocated

2.1.2 Composite Port

Full Duplex

Speed

Synchronous up to 128 Kbps

Asynchronous from 300 to 115,200 bps

Interface

RS-232D, implemented in RJ-45, 8 position connector

2.1.3 Network Management Port Commands

- Show Network Status
- Show Port Configuration
- Change Port Configuration
- Change Mux Parameters
- Configure Network
- Configure Modem
- Configure Radio
- Show / Change ID
- Activity Counters
- Zero Activity Counters
- Flow Control
- Test Tools
 - Capture Port
 - Copy Command
 - Show RS232
 - Network Loop
 - Test Message
 - Remote Test Loop
 - Monitor Port Tx
 - Monitor Port Rx
 - NMP Parity
 - Port Reset
 - Reset Mux
- Type
- Repeat Last Command
- Disconnect NMP

2.2 Environmental

Operation: -40 to +75° C, 10 to 95% relative humidity
Storage: -40 to +85° C, 10 to 95% relative humidity

2.3 Physical / Electrical

10¼" W x 9¾" D x 2½" H
120 VAC external power supply
Optional 240VAC power supply available
30 watts, .25 amps

2.4 Other Specifications

Operating Modes

- Multiplexing
- Network Loopback
- Port Loopbacks

Front Panel Indicators

- Power
- Activity
- Line Error
- Modem Ready
- Port 1 Setup
- Loopback

Front Panel Switches

- Loopback
- Setup
- Reset

2.5 Optional Built-In DSU/CSU Specifications

- Compatible with Common Carrier digital signalling
- 56 or 64 Kbps
- 4 wire digital line
- Can be used as high speed 4 wire line driver in 56K mode

2.6 Optional Built-In Wireless Modem Specifications

- Frequency Hopping
- Spread Spectrum
- 900 MHz or 2.4 GHz
- Range to 20 Miles
- Asynchronous to 115.2 Kbps

3. INSTALLATION

3.1 Unpacking

Remove the SR multiplexer from the shipping container and examine it carefully for external damage. If shipping damage is apparent, notify the shipper immediately.

The following accessories are included with all SR multiplexers:

- external power supply (AC powered units only)
- manual
- warranty, maintenance contract and repair information
- Modem to Composite cable (black) for connecting the SR to an external modem or DSU/CSU
- Network Management Port cable (green) for connecting the SR network management port to an asynchronous terminal or PC for configuration
- If your unit has the optional built-in DSU/CSU, a cable is also included for connection to the phone line.

3.2 Setup

The composite port must be configured properly for the type of link used (Sync or Async). In addition, each data port must have the proper speed, parity and flow control settings. This is done using the network management port CN and CP commands (see Section 5).

3.3 Using Leased Line Modems

In this section, a reference to modem includes modems, digital radios or DSU/CSUs for leased line installations.

Connect the modems to the phone line and power ON the modems. Confirm the presence of carrier at each modem. If carrier is not detected at both ends, recheck the option settings. If carrier is still not present, check the cable from the telephone line to the modem. If everything is correct and still no carrier call the manufacturer of the modem or contact the telephone company for assistance.

Connect the SR composite port to the modem. A two foot RJ45 to DB-25 male cable connects the composite port of the SR (the RJ45 connector second from the left when viewed from the rear) to the data port of the modem (usually a DB-25 female connector). See Section 6 for cabling information.

Connect the multiplexers to power.

Power, Activity and Modem Ready indicators on the front panel of the SR must be ON indicating the on-line condition. (See Section 4).

3.4 Using Dial-Up Modems

To configure your SR Multiplexers to work with DCB dial-up modems first connect the modems to the multiplexers using the Modem to Composite cable supplied (not required for internal modems). Next attach a terminal or PC to the SR Network Management Port using the green cable and the appropriate adapter (supplied). Set the terminal for 9600 8,N,1 and no flow control. When you see "AT YOUR COMMAND >>", follow the instructions below. User responses are shown in **BOLD**.

3.4.1 Host Multiplexer (ANSWER)

```
AT YOUR COMMAND >> CN<Enter>
```

```
CONFIGURE NETWORK
```

```
-----
```

```
SYNC MODEM  
LEASED LINE  
ERROR CORRECTION ON
```

```
SYNC or ASYNC modem? [S/A] >> A<Enter>  
ASYNC rate? [9600 / 19200 / 38400 / 57600 / 115200] >> 57<Enter>  
Leased or Dialup Line? [L/D] >> D<Enter>  
Enable Error Correction? [Y/N] >> Y<Enter>  
One-Touch Dialing? [ATD / DTR Dial / OFF] >> OFF<Enter>  
Disconnect timeout? [1 to 99 min; 0=Disable] >> 0<Enter>
```

```
ASYNC MODEM: 57600  
DIALUP LINE  
ERROR CORRECTION ON  
ONE-TOUCH DIALING: OFF  
DISCONNECT TIMEOUT: DISABLED
```

NOTE: Use CM command to configure network modem.

```
AT YOUR COMMAND >> CM<Enter>
```

```
*** CONFIGURE MODEM - Type ESC ESC to stop  
at<Enter>  
OK  
at&f &q6 s0=1 &w<Enter>  
OK
```

Type **<Esc><Esc>** to return to AT YOUR COMMAND.

```
*** END CONFIGURE MODEM
```

```
AT YOUR COMMAND >>
```

3.4.2 Remote Multiplexer (ORIGINATE)

AT YOUR COMMAND >> **CN<Enter>**

CONFIGURE NETWORK

SYNC MODEM
LEASED LINE
ERROR CORRECTION ON

SYNC or ASYNC modem? [S/A] >> **A<Enter>**
ASYNC rate? [9600 / 19200 / 38400 / 57600 / 115200] >> **57<Enter>**
Leased or Dialup Line? [L/D] >> **D<Enter>**
Enable Error Correction? [Y/N] >> **Y<Enter>**
One-Touch Dialing? [ATD / DTR Dial / OFF] >> **AT<Enter>**
ATD command? [ATDS0 / Custom] >> **C<Enter>**
Enter ATD command [20 char max] >> **ATDnnn-nnnn<Enter>**

Note: Replace nnn-nnnn with the phone number of the HOST Multiplexer.

To configure a **full time link** with automatic redial perform the following:

Disconnect timeout? [1 to 99 min; 0=Auto-Redial] >> **0<Enter>**
Auto-redial timeout? [15 to 900 sec] >> **15<Enter>**

To configure an **on-demand link**, perform the following:

Disconnect timeout? [1 to 99 min; 0=Auto-Redial] >> **nn<Enter>**
Send SR call progress messages? [Y/N] >> **Y<Enter>**

ASYNC MODEM: 57600
DIALUP LINE
ERROR CORRECTION ON
ONE-TOUCH DIALING: ATD Dialing - [ATDnnn-nnnn]
DISCONNECT TIMEOUT: Auto-Redial Enabled
AUTO-REDIAL TIMEOUT: 15 sec.

NOTE: Use CM command to configure network modem.

AT YOUR COMMAND >> **CM<Enter>**

*** CONFIGURE MODEM - Type ESC ESC to stop
at<Enter>
OK
at&f &q6 &w<Enter>
OK

Type **<Esc><Esc>** to return to AT YOUR COMMAND.

*** END CONFIGURE MODEM

AT YOUR COMMAND >>

3.4.3 On-Demand One Touch Dialing

To establish an on-demand connection to the host press any key on any terminal connected to the remote multiplexer. When you see "SR: Connected..." you should be able to log in from all remote terminals. The multiplexer will terminate the connection if there is no activity to or from any port for the period of time set as the Disconnect Timeout. To reestablish the connection, press any key on any terminal.

3.5 Optional Built-In 56 or 64 Kbps DSU/CSU

The optional DSU/CSU is configured using DIP switches accessible from the rear of the unit. See Section 4 for a description and location of these switches. The default settings should be correct for most applications.

For line driver applications over customer owned wire (56K only), set one unit for Master Clock and the other unit to Slave Clock.

3.6 Optional Built-In Wireless Modem (Model SR-04W)

Your SR-04 multiplexer with internal wireless modem was configured at the factory to work in most applications. If changes are required to the modem settings, connect a terminal to the multiplexer network management port (See Section 5) and follow the procedure below. User responses are shown in **BOLD**.

AT YOUR COMMAND >> **CR**<Enter>

*** CONFIGURE NETWORK RADIO - Type ESC ESC to stop
*** WARNING: Network DCD is ON

MAIN MENU
Version 2.44 10-20-2004
Standard Hop Table
Modem Serial Number 918-8553

(0) Set Operation Mode
(1) Set Baud Rate
(2) Edit Call Book
(3) Edit Radio Transmission Characteristics
(4) Show Radio Statistics
(5) Edit MultiPoint Parameters
(6) TDMA Menu
(8) Chg Password
(Esc) Exit Setup

Enter Choice

Make the required changes following the menu prompts. See the DCB-115 manual for options. Type Esc Esc to exit.

<Esc><Esc>

*** NOTE: If you changed the radio baud rate, enter
*** the new rate now, otherwise press ESC.

CONFIGURE NETWORK

ASYNC MODEM: 57600 BPS
HALF-DUPLEX
IGNORE NETWORK DCD

ASYNC rate? [4800/9600/19200/38400/57600/115200] >> <Esc>

*** END CONFIGURE RADIO - Please wait for RESET!

SR4 Standard V5.x ID:

AT YOUR COMMAND >>

3.7 Cabling

Cabling between the multiplexer and the computer ports or terminal devices is a common source of installation problems. The SR must have data from attached terminal devices or computer ports, as an input on Position 6 of the RJ45 connector. Data from the SR to any attached equipment will be transmitted on position 5 of the RJ45 connector. See paragraph 6.1 for position location on the RJ45 connector.

See Section 6 to determine the correct cables for your computer and terminal devices.

3.8 Parity Considerations

SR multiplexers transfer all character bits whether it is 7 data bits plus parity or 8 data bits. The SR does not verify parity for each character transferred. Consequently, the parity setting of the devices at either end of an SR channel must match. Because of this ability to transfer 8 bits transparently, the SR can transfer graphic characters, binary files and support "PC terminals."

Why XON/XOFF parity settings?

Parity only becomes an issue if you are using XON/XOFF flow control. The SR must know what to send for the parity bit of the XON and XOFF characters. The attached devices will not recognize the flow control characters if the parity is not correct. Also, the SR must know which character to interpret as an XON or XOFF when received from the attached device.

Remote site XON/XOFF parity settings.

When setting XON/XOFF flow control at a remote site, set the parity of the SR port to match the attached device. If the device is set for EVEN parity, set the SR port for XE (XON/XOFF Even). If the attached device is set for ODD parity, set the SR port for XO (XON/XOFF Odd). If you are using 8 data bits and no parity, set the SR port for XS (XON/XOFF Space). For the XON/ XOFF characters, the SPACE parity setting is the same as 8 data bits no parity.

Host site XON/XOFF parity settings.

Since the host computer can process data faster than we can type, it will never issue flow control to stop the inflow of data. If an XON or XOFF character is issued by the CPU, it is for a status or initialization function and not flow control. Because of this activity, the host SR must pass the XON/XOFF character to the remote end and not act upon it. To accomplish this task, the SR has an XON/XOFF Transparent setting. When set for Transparent, the SR will pass the XON/XOFF characters to the other end without taking flow control action. When using XON/XOFF flow control, set the host computer side SR ports to XT (XON/XOFF Transparent).

Host site parity determination.

When the host site SR port is set for XT (XON/XOFF Transparent), parity is not specified for the XON or XOFF characters to be issued. The SR will determine the parity for the XON/XOFF characters as follows:

1. If the flow control setting is for XT (XON/XOFF Transparent), the SR will interrogate the other SR multiplexer for the parity setting of the corresponding port.
2. If the corresponding port is set for XE(Even), XO(Odd), XM(Mark) or XS(Space) flow control, the SR will use the matching parity.
3. If the corresponding port is set for XT(Transparent) or any of the CTS flow control options, the SR will default to Space parity (same as 8 data bits-no parity).

3.9 Flow Control and Rate Tips

Individual port options are set through the network management port or through port 1 setup. (See Section 5).

Flow control options are the most critical and the most common source of installation problems. If the flow control is improperly implemented data loss may occur.

If you are using software flow control (Xon/Xoff) double check the parity settings. Make sure that the Parity is set the same at the CPU, remote SR and attached devices. If your system uses 8 bits, no parity (8,N,1), set the host multiplexer ports for Xon/Xoff Transparent (XT) and set the remote ports for Xon/Xoff Space (XS).

If half of your characters are good and half are bad, there is a parity setting mismatch between the CPU and terminal device.

When using hardware flow control, double check the cabling (see Section 6). For input flow control (data flow into the SR) Clear To Send, position 7 of the RJ45 connector, is used. For output flow control (data output from the SR to a terminal or printer) Busy high or low, position 3 is used.

Using the network management port, issue the "AC" command (Activity) to see information about port errors and retransmissions. Port errors indicate either speed, parity or both are incorrectly set. The "SC" command (Show Configuration) can be used to confirm each port is set correctly.

3.10 Resetting Factory Defaults

The factory default settings for the SR multiplexer ports are as follows:

Data Ports:

Loop	OFF
Flow Control	XS (XON/XOFF Space)
Rate	9600

Composite Port:

Modem type	SYNC
Line type	Leased Line
Error Correction	ON

To reset the unit to factory defaults use the !R command from the network management port or perform the following steps using the front panel switches:

1. Depress and hold the SETUP switch while depressing the RESET switch.
2. Be sure to continue to hold the SETUP switch until its LED has gone OFF and returned ON.
3. Release and depress the SETUP switch again to return management control to the network management port.
4. All port settings should be at the factory defaults. Use the SC (Show Configuration) command to check the port settings.

4. CONTROLS AND INDICATORS

4.1 Switches

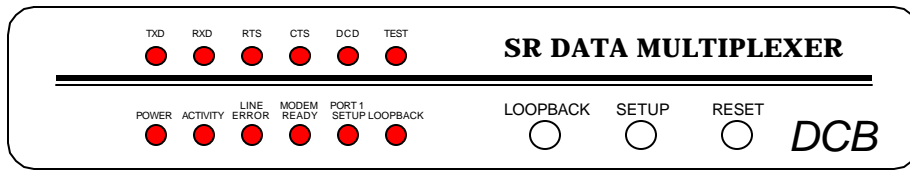

4.1.1 Front Panel Switches (shown with built-in DSU)

Setup – Maps the network management port commands to the terminal attached to data port 1. When Port 1 Setup is active, the indicator is on.

Loopback – Initiates a bi-directional composite port loopback. The loopback is active when the indicator is on.

Reset – Performs a hardware reset of the multiplexer.

4.1.2 Optional Built-In DSU Switches

The DSU switches are located at the rear of the unit. Switch functions are shown in the following table:

Switch	Down	Up
1	56K	64K (optional)
2	Slave Clock	Master Clock
3	Must Be Down	
4	RTS Normal	RTS Forced ON
5	Normal	Local Loop ON
6	Not Used	

NOTE

RTS mode (sw 4) is active in 56Kbps mode only. In 64Kbps mode, RTS is forced on.

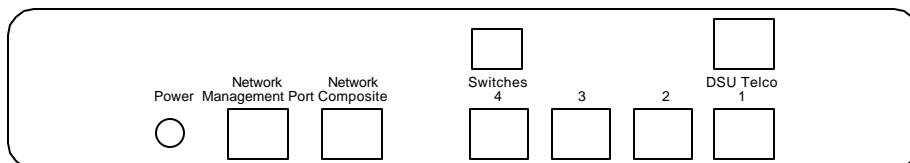

For normal operation with a telephone company line, set the DSU for SLAVE clock timing (switch position 2 DOWN). For in-house line driver applications (56K only), set the host DSU for MASTER timing (switch position 2 UP). The remote unit should remain set for Slave clock.

4.2 Multiplexer Indicators

POWER – is ON when the SR is connected to power.

ACTIVITY

ON – multiplexing mode with no data activity.

FLICKERING – multiplexing mode with data activity (the ACTIVITY indicator flickers off for every 16 blocks of data).

FLASHING SLOWLY – Data Carrier Detect has been lost for over 45 seconds indicating a major composite link problem.

LINE ERROR – flashes when an error is detected in received data.

MODEM READY

ON – Data Carrier Detect and Clear to Send are present from the composite link device indicating an active composite link.

FAST FLASHING – composite link is active but there are 10 blocks of data outstanding without a response from the remote multiplexer.

SLOW FLASHING – composite link modem is retraining and flashing Data Carrier Detect or Clear to Send upon each retrain indicating a problem with the composite link.

OFF – Data Carrier Detect or Clear to Send is not present from the composite modem or DSU/CSU indicating a problem with the composite link.

PORT 1 SETUP – is ON when the network management port functions have been mapped to data port 1 by depressing the front panel switch. To return these functions to the network management port, depress the front panel switch again.

LOOPBACK

ON – The bidirectional composite loopback has been activated by depressing the front panel switch. To return to normal operation, depress the front panel switch again.

FLASHING – One or more port loopbacks are enabled.

The following table shows the relationship between composite DCD and CTS and the front panel MODEM READY and ACTIVITY indicators.

DCD	CTS	MODEM READY	ACTIVITY
HI	HI	ON	ON
LO	LO	OFF	Flash
LO	HI	OFF	Flash
HI	LO	OFF	ON

4.3 Optional DSU/CSU Indicators

TxD	Flashing	Data is being sent over the link.
RxD	Flashing	Data is being received from the link.
RTS	ON	Forced on or high from the multiplexer.
	OFF	No RTS from the multiplexer.
CTS	Follows RTS	CTS signal to the multiplexer.
DCD	ON	Normal condition.
	OFF	No carrier signal received from the far end.
TEST	ON	Unit is in loopback (DIP switch 5 UP)
	Flashing	Telephone line in loopback.

5. NETWORK MANAGEMENT PORT

5.1 Introduction

The Network Management port (NMP) is used to configure the SR multiplexer for proper operation. This connection must be used to configure the SR composite and data ports. The NMP can also be used to configure remote SR ports after a link is established between the host and remote sites.

5.2 Connections and Setup

Connection to the NMP is made either through a port on the rear of the multiplexer or by using Port 1 Setup.

5.2.1 Port 1 Setup

The easiest way to access the NMP functions is by using a terminal connected to port 1 of the multiplexer. A switch located on the front panel performs this function. See paragraph 4.1.1 for information. This option cannot be used if a printer is connected to port 1.

5.2.2 Dedicated Terminal or PC

The NMP functions are also available through a port on the rear of the unit labeled Network Management Port. To connect a dedicated terminal to this port, use the green cable provided and the appropriate adapter for either a terminal or PC. Set the terminal device for 9600 bps, 8 data bits, no parity, one stop bit and no flow control.

5.2.3 Dedicated Modem

For remote access to NMP functions, a dial-up modem may be connected to the Network Management Port. You must fix the DTE interface speed of the modem at 9600 bps, 8 data bits, no parity and one stop bit. Refer to your modem manual for appropriate setup procedures. Use the appropriate cable from paragraph 6.3.3 for connection.

5.3 Using the Network Management port

To activate the NMP, press the ENTER key. When you see **AT YOUR COMMAND >>**, the NMP is active and ready for your commands. Type H <Enter> to display the command set.

5.4 Commands

5.4.1 Help (H or ?)

<u>COMMAND</u>	<u>LOCAL</u>	<u>REMOTE</u>	<u>PARAGRAPH</u>
Show: Network	SN		5.4.2
Config	SC	RSC	5.4.3
Change: Port Config	CP	RCP	5.4.4
MUX Param	CO	RCO	5.4.5
Config Network	CN		5.4.6
Config Modem	CM		5.4.7
Config Radio	CR		5.4.8
Set ID	ID	RID	5.4.9
Activity Counters/Zero	AC/Z	RAC	5.4.10
Flow Control	FC		5.4.11
Test Tools	TT		5.4.15
Type	TY	RTY	5.4.12
Repeat Last Command	*		5.4.13
Disconnect NMP	BYE		5.4.14

This Help screen shows the choice of commands available. The commands allow you to display the selected options (Show network and configuration), configure the SR (Configure ports and Set ID), and perform many different diagnostic functions such as send a test message, monitor data, perform loopbacks, show flow control state, show activity and other useful tests.

5.4.2 Show Network (Configuration)

The Show Network (SN) command displays the current network (composite port) configuration and multiplexer mode of operation.

Configuration parameters include SYNC or ASYNC, LEASED LINE or DIAL-UP, ERROR CORRECTION ON or OFF and one touch dialing information if enabled.

Operating modes are OFF LINE, ON-LINE MUXING, and LOOPBACK MUXING.

5.4.3 Show (Port) Configuration

The Show Config (SC) command shows the current port configuration settings for either the local or the remote (RSC) ports. Port numbers may be included with this command to limit the display range. If no port numbers are included, settings for all ports are shown. Use this command to verify proper port configuration.

NOTE

Several commands allow port numbers or port number ranges to be included on the command line. When port numbers are included, the syntax is as follows:

(Command)1	Port 1
(Command)1,2,6	Ports 1, 2 & 6
(Command)1 2 6	Ports 1, 2 & 6
(Command)2-6	Ports 2 thru 6
(Command)1,5-8	Ports 1 and 5 thru 8

5.4.4 Change Port Configuration

The Change Port Config (CP / RCP) command sets the data port loopback, flow control and rate configuration for each data port. Follow the prompts and examples on the screen to select the port(s) and parameter(s) you wish to change. One or more ports may be set with a single command by selecting a range of port numbers. The factory default setting is Xon/Xoff Space, 9600 bps.

With optional firmware, this command is also used to set ports for 8 data bits plus EVEN, ODD, MARK, or NO parity.

5.4.5 Change Multiplexer Parameters

The CO / RCO command allows configuration of global data port parameters. These include RTS Data Gate and Data Carrier Detect. For most systems, these settings will never have to be changed.

The RTS Data Gate is used to insure that no data is transmitted from a data port unless RTS is high from the attached device. This will sometimes stop "streaming" ports.

The state of Data Carrier Detect is critical to proper operation of some host computers. Many computers depend on DCD to issue login prompts. If your host does not issue logins properly, you may need to change this setting.

5.4.6 Configure Network

The Configure Network command (CN) allows configuration of the multiplexer composite port for asynchronous and/or dial-up operation. This command can also be used to disable error correction if required.

See paragraph 3.4 for step-by-step instructions for dial-up operation.

Type two consecutive ESC characters to return to the AT YOUR COMMAND >> prompt.

5.4.7 Configure Modem

The Configure Modem command (CM) establishes a direct connection between the network management port and the composite port. This allows the operator to give commands directly to an attached dial-up modem.

Type two consecutive ESC characters to return to the AT YOUR COMMAND >> prompt.

5.4.8 Configure Radio

The Configure Radio command (CR) establishes a direct connection between the network management port and the optional built-in wireless modem. The command is used to change configuration settings in the wireless modem. See paragraph 3.6.

5.4.9 Set ID

The Set ID (ID / RID) command allows you to set or change either the local or remote multiplexer identifier. IDs can be a maximum of 15 characters in length. Pressing <Enter> with no entry will leave the ID unchanged.

5.4.10 Activity Counts / Zero

The Activity Counts (AC / RAC) command shows transmit and receive data statistics for all ports. The data are presented in terms of blocks of information sent and received by the network and each data port. Error counts are also shown. A range of ports may be included with this command to reduce the number of ports shown.

The Z command is used to zero the counters so that current activity can be monitored.

5.4.11 Flow Control

The Flow Control (FC) command displays the current port flow control status for both local and remote ports. A port range may be included with this command.

5.4.12 Type

The Type (TY) command displays information about the local multiplexer including firmware version, number of ports and multiplexer ID. The Remote Type (RTY) command is used to display similar information about the remote multiplexer.

5.4.13 Repeat Last Command

To repeat the last command, simply press the * key. This is handy for repeating screens of constantly changing data.

5.4.14 Disconnect NMP

The BYE command toggles the CTS output from the Network Management port. This is used to disconnect equipment such as dial-up modems or the DCB Access Switch.

5.4.15 Test Tools

The Test Tools (TT) menu summarizes the test and troubleshooting commands. These commands are listed separately to reduce the clutter in the main help list, but are always available from the command prompt.

<u>COMMAND</u>	<u>LOCAL</u>	<u>REMOTE</u>	<u>PARAGRAPH</u>
Capture Port	CA#	RCA#	5.4.16
Copy Command	CC#	RCC#	5.4.17
Show RS232	SR	RSR	5.4.18
Network Loop/Quit	NL/QNL		5.4.19
Test Message	TM#	RTM#	5.4.20
Remote Test Loop		RTL#	5.4.21
Monitor Port Tx	MT#		5.4.22
Monitor Port Rx	MR#		5.4.22
NMP Parity	P		5.4.23
Port Reset	PR		5.4.24
Reset MUX	RESET	RRESET	5.4.25

5.4.16 Capture Port

The Capture Port command (CA#) permits the network management port to capture any of the local ports. While this command is active, the normal data path is interrupted and a two-way communication link is established between the network management port and the captured port. A port number must be included on the command line.

The Remote Capture port command (RCA#) connects the network management port to a remote multiplexer port. During this time, normal data communications are suspended and the NMP terminal can talk directly to captured port.

The Capture commands are active until two consecutive ESC characters are issued.

5.4.17 Copy Command

The Copy Command (CC#) is used for training. This command is used when the instructor is at the host site and the trainee is at the remote. The command is followed by the port number to which the trainee's terminal is attached.

After the command is entered, all data from the local port will be displayed on both terminals. Keyboard inputs from either terminal will be sent to the host port.

The Remote Copy Command (RCC#) performs the same function when the instructor is located at the remote site. This command is used only at the remote site.

The Copy commands are active until two consecutive ESC characters are issued by the instructor.

5.4.18 Show RS-232

The Show RS-232 (SR) command shows the current state of RS-232 control signals on the local ports. A range of port numbers may be included to limit the display.

The Remote Show RS-232 (RSR) command shows the status of RS-232 control signals at the remote ports. As with the SR command, a range of port numbers may be included on the command line.

5.4.19 Network Loopback

The Network Loopback (NL) command enables a bi-directional loopback of the composite port. Use the QNL command to disable the loopback.

5.4.20 Test Message

The Test Message (TM#) command sends a Quick Brown Fox... message to a local port. The QBF message continues until any key is pressed on the network management port terminal. A local port number must be included on the command line.

The Remote Test Message (RTM#) command sends a QBF test message to a remote port. The message continues until any key is pressed on the network management port terminal. The number of the remote port must be included on the command line.

5.4.21 Remote Test Loop

The Remote Test Loop (RTL#) command is used to test a data path from end to end. This command enables port loopback in the remote multiplexer, then sends a test message to that port. If everything is working correctly, the test message is displayed on the network management port terminal. A remote port number must be included on the command line.

5.4.22 Monitor Port TX or RX

The Monitor Port TX (MT#) command monitors data transmitted from the selected port to the corresponding port of the remote multiplexer. The Monitor Port RX (MR#) command monitors data received by the selected port from the corresponding port of the remote multiplexer. A local port number must be included on the command line.

When port monitor is active, two ESC characters are needed to end the test.

5.4.23 NMP Parity

The NMP Parity command (P) sets the parity for the network management port. The factory default is SPACE (8,N,1).

5.4.24 Port Reset

The Port Reset (PR) command is used to reset flow control to hung ports. A range of local port numbers or ALL may be included with this command. Flow control leads at both the local and remote ports are reset.

5.4.25 Reset Mux

The Reset Mux (RESET) command performs a local multiplexer reset. To reset the remote multiplexer use RRESET.

6. INTERFACE SIGNALS AND CABLING

6.1 Connector Location and Pin Reference

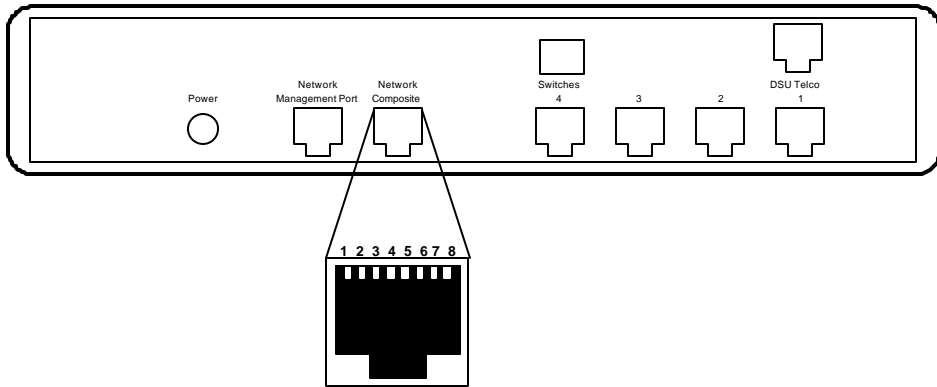

SR 4 Rear Panel and RJ-45 Jacks

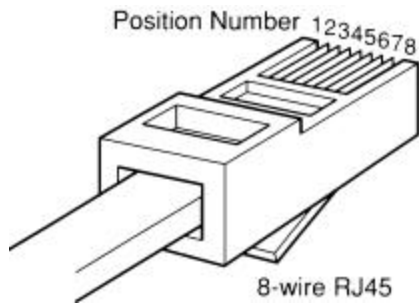

RJ-45 Plug Positions

6.2 Port Interface

6.2.1 Composite Port (RJ-45)

<u>Pin</u>	<u>Signal</u>	<u>In/Out</u>
1	Receive Clock	IN
2	Transmit Clock	IN
3	Data Carrier Detect	IN
4	Signal Ground	
5	Transmit Data	OUT
6	Receive Data	IN
7	Request to Send	OUT
8	Clear to Send	IN

6.2.2 Data Ports (RJ-45)

<u>Pin</u>	<u>Signal</u>	<u>In/Out</u>
1	Data Set Ready	OUT
2	Data Carrier Detect	OUT
3	Busy	IN
4	Signal Ground	
5	Receive Data	OUT
6	Transmit Data	IN
7	Clear to Send	OUT
8	Request to Send	IN

6.2.3 Network Management Port (RJ-45)

<u>Pin</u>	<u>Signal</u>	<u>In/Out</u>
1	Not Used	
2	Not Used	
3	Data Carrier Detect	IN
4	Signal Ground	
5	Transmit Data	OUT
6	Receive Data	IN
7	Request to Send	OUT
8	Clear to Send	IN

6.2.4 Optional Built-In DSU Interface (RJ-48S)

<u>Pin</u>	<u>Signal</u>	<u>In/Out</u>
1	Transmit Data	OUT
2	Transmit Data	OUT
7	Receive Data	IN
8	Receive Data	IN

6.3 Cables

6.3.1 Composite Port to Modem

A two foot composite to modem cable is included with each SR multiplexer. The configuration is as follows:

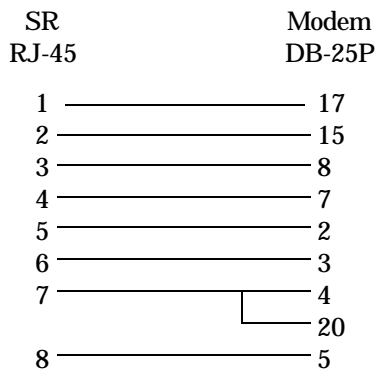

6.3.2 Data Ports to Host Computer, Terminal or Printer

Configured as DTE

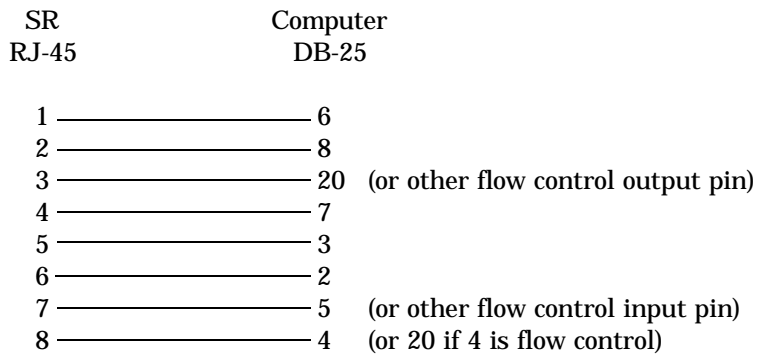

6.3.2 Data Ports to Host Computer, continued

Configured as DCE

SR RJ-45	Computer DB-25
1	
2	20 (or 4 if 20 is flow control)
3	5 (or other flow control output pin)
4	7
5	2
6	3
7	4 (or other flow control input pin)
8	8

To a PC Com Port

SR RJ-45	Computer DB-25S	DE-9S
1	6	or 6
2	8	or 1
3	4	or 7
4	7	or 5
5	3	or 2
6	2	or 3
7	5	or 8
8	20	or 4

6.3.3 Network Management Port

To a TERMINAL

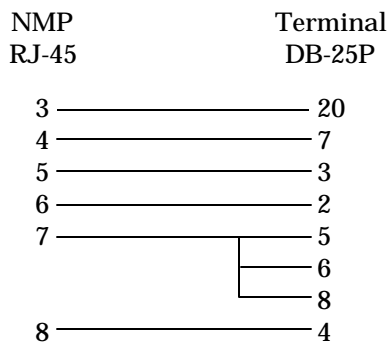

To a PC using terminal emulation

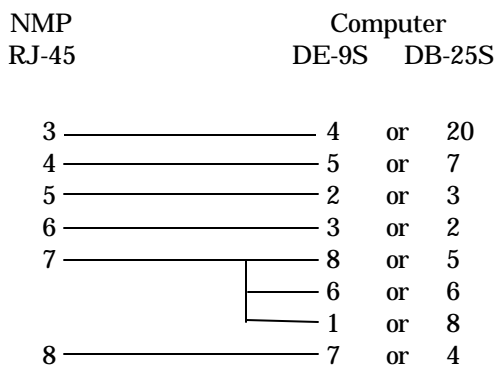

To a dial-up MODEM for remote access

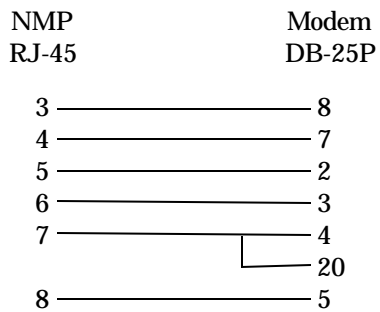

6.4 Signal Paths through Multiplexers

The following diagram shows the signal flow between data ports of two SR multiplexers.

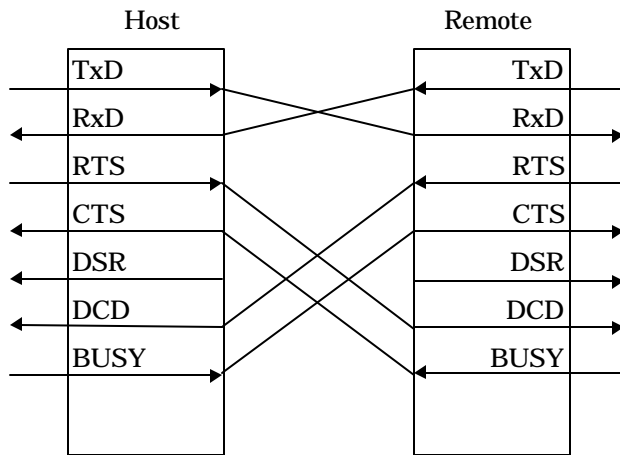

Transmit Data to Receive Data is the normal required path for data flow.

RTS to DCD is a hardware handshake path used to wake up the remote device. Many host computers require DCD to issue a login prompt.

Busy to CTS is the hardware flow control path. For CTS/Busy flow control, the hardware flow control pin of the attached device must be wired to Busy on the multiplexer.

The DSR output of the multiplexer port is always asserted (high).

7. TROUBLESHOOTING

7.1 General Approach

When troubleshooting problems, a rational plan can save you many hours of frustration. The following is a brief outline of standard troubleshooting procedures.

1. Gather the facts to determine the exact nature of the problem.
2. Draw a picture of the system showing the equipment at both the host and remote ends and the phone lines or in-house wiring. Use this as a reference to note your observations, test steps and test results. A picture keeps you focused and often saves duplicate effort.
3. Record the front panel indications before changing anything. This is an important part of fact gathering
4. If you change anything, change only one thing at a time.
5. Use the built-in test functions, especially the loopback tests and record your results.

7.2 Loopback Tests

It is best to begin loopback testing at the remote terminal and work toward the host. If all the loopbacks are successful, the data communications equipment and the terminal are working correctly.

Put the remote multiplexer port in loopback and have someone type alpha characters on the keyboard of the affected terminal. If the characters appear correctly on the screen, the port is working. Next loop the associated port of the host multiplexer. If characters again appear correctly, the communications link and the ports on both multiplexers are working correctly. The problem then is with the host computer port or the cable between the host computer and the multiplexer.

Port loopbacks can be turned on and off from the Network Management port of the multiplexer. If a NMP terminal is not available, port loopback can be enabled using the Port 1 Setup function of the remote multiplexer

7.3 Installation Troubleshooting, Modems or DSUs

First, set up the Modems or DSUs without connecting the multiplexers. If DSUs are used they should be set to constant carrier, also called forced Request To Send, or constant RTS.

Carrier Detect should be ON at both locations.

7.4 Installation Troubleshooting, Multiplexers

Before trying terminals, make sure the multiplexers are able to “see” each other. Use the RTY command to verify a response from the remote multiplexer. If you get a correct response to RTY, the link is up and the multiplexers are communicating.

7.5 Installation Troubleshooting, Terminals

Terminal problems typically fall into four categories:

1. The terminal or printer gets no data
2. The terminal or printer gets “garbage” data
3. Blocks of data are lost
4. Terminals or printers seem to “hang”.

When a terminal gets no data, check to see the cables are wired correctly and that flow control is set properly.

If the terminal gets “garbage” data, check the speeds of the host and remote multiplexers, the terminal and the computer ports to make sure they match.

Blocks of data are lost most often when data is sent to a printer or a lot of data is being displayed on a terminal. Most of these problems are due to flow control not matching between the printer or terminal and the multiplexer.

If terminals and printers work for a while and then “hang”, check the flow control settings. When Xon/Xoff flow control is set to a different parity on the multiplexer than on the terminal or printer, the result is either a “hung” device that is flow controlled off but never back on, or a device that is never flowed off causing buffer overflow and lost data.

7.6 Assistance

If you need assistance troubleshooting your system, contact DCB customer support at (217) 897-6600 between 8:00 am and 5:00 pm central time Monday through Friday.

8. WARRANTY

DCB multiplexers are warranted to be free of defects in materials and workmanship for two years. Data Comm for Business will repair or replace any equipment proven to be defective within the warranty period. All warranty work is F.O.B. Dewey, IL. This warranty is exclusive of abuse, misuse, accidental damage, acts of God or consequential damages, etc. DCB liability shall not exceed the original purchase price.

All equipment returned for repair must be accompanied by a Returned Material Authorization (RMA) number. To receive an RMA number, call (217) 897-6600 between the hours of 8 AM and 5 PM central time. Equipment must be shipped prepaid to DCB and will be returned at DCB's expense.

Ship returned items to:

Data Comm for Business
2949 CR 1000E
Dewey, IL 61840

Data Comm for Business, Inc.
PO Box 6329
Champaign, IL 61826-6329

Tel (217) 897-6600
Fax (217) 897-1331
Email support@dcbnet.com