

# T-Monitor E-Monitor

---

## TABLE OF CONTENTS

---

**SECTION 1 - DESCRIPTION ..... 2**

**SECTION 2 - SPECIFICATIONS ..... 3**

**SECTION 3 - INSTALLATION ..... 5**

**SECTION 4 - FRONT PANEL INDICATORS ..... 7**

**SECTION 5 - INTERFACE SIGNALS AND CABLES ..... 8**

**SECTION 6 - TROUBLESHOOTING ..... 12**

**SECTION 7 - WARRANTY..... 13**

Data Comm for Business, Inc.  
PO Box 6329  
Champaign, IL 61826-6329  
217-897-6600  
[www.dcbnet.com](http://www.dcbnet.com)

May 27, 2009

---

## 1. DESCRIPTION

---

The DCB T-Monitor and E-Monitor use 4-wire repeater technology to provide a monitor point for T1 or E1 lines. The T/E-Monitor uses repeater circuits on all data paths. This active repeater function is superior to simple passive monitor devices. For some T1 and E1 circuits, the double termination of passive monitor devices will attenuate the signal enough to generate data errors. The T/E-Monitor units are the solution to this attenuation problem. The units provide both electrical isolation and actively repeat the signal.

The circuitry is rated to  $-36$  dB dynamic range at the T-1 rate of 1.544 Mbps and  $-43$  dB dynamic range at the E-1 rate of 2.048 Mbps. Solid copper 22 AWG, two twisted pair is the preferred cable for connection between the units (we do not recommend CAT5 cable). Connection to the Monitor is made through RJ48 modular connectors or 4-wire screw down terminal blocks. Each Monitor comes standard with three screw down terminal blocks and two RJ48 connectors. If only RJ48 connections are desired extra RJ48 adapters (part number 9502122 to connect to telco, 9502172 to connect to customer equipment) can be ordered.

The T/E-Monitor is transparent to the type of data sent over the T1 or E1 link. The data can be D-4, ESF, PRI, G.703, G.704, etc.

The DCB T-Monitors and E-Monitors are powered by a small wall-mount 120 or 240VAC transformer (included). DC power options are available (see below).

### Features

- Actively monitor T1 and E1 lines
- Actively repeats the T1 and E1 signals
- RJ48 or screw down connectors
- Simple connection to 4-wire circuits
- Power options 120 or 240 VAC; 12, 24, 48, or 125 VDC
- 1U high rack mountable, 1, 2, or 3 x 19" rack
- 20 slot rack chassis option
- DIN mount option

### Applications

- Monitor T1/E1 line to extract SS7 info
- Monitor T1/E1 lines for voice applications
- Monitor T1/E1 lines for data analysis

---

## 2. SPECIFICATIONS

---

### 2.1 General

T1 or E1 monitor output  
Actively repeats T1 or E1 bi-polar signals

Indicators  
Power

#### Accessories

RJ48 wiring adapters P/N 9502122 and 9502172 (included)  
RJ45 to RJ45 straight through cable P/N 9500095  
RJ45 to RJ45 crossover cable P/N 9500099  
Rack shelf, 1U for 1 to 3 T-Monitors  
20 slot, 4U high 19" rack mount chassis

### 2.2 T1

Tx Output Level: 0.5dBdsx, 17.0dBm, 6.3v p-p  
Rx Input Sensitivity: -36dB

### 2.3 Wire

Two twisted pair solid copper

### 2.4 T1/E1 In and Out Connectors

RJ48 modular	9502122	9502172
Pin 1 - In	Receive	Transmit
Pin 2 - In	Receive	Transmit
Pin 4 - Out	Transmit	Receive
Pin 5 - Out	Transmit	Receive

4-Wire terminal block  
Receive - In  
Receive - In  
Transmit - Out  
Transmit - Out

Connect the transmit pair of one Monitor to the receive pair of the other Monitor. Pairs are not polarity sensitive. Units are supplied with 3 screw down and 2 RJ48 adapter connectors (one each 9502122 and 9502172)

2.5 Physical/Electrical

5.5" x 7.5" x 1.5"  
100 ohm T-1 interface, 120 ohm E1 interface  
2 lbs including wall transformer  
120 VAC external wall transformer included  
Optional 240 VAC; 12, 24, 48, 125 VDC  
30 ma

2.6 Environmental

-40 to +70 C operating temperature

---

### 3. INSTALLATION

---

#### 3.1 Unpacking

The following is included with each unit:

- Unit and external power supply.
- Two RJ48 to terminal block adapters. One provides an equipment interface the other provides a network interface.
- Manual
- Information regarding warranty, maintenance contracts and repair.

#### 3.2 Location

Place the unit in a clear area where you can reach the rear panel to connect the cables. The unit has an external power supply that requires a 120 VAC outlet. The total power cord length is about 6 feet.

#### 3.3 Connections

On the unit, **transmit is an output, receive is an input**. The Monitor pairs are output. When connecting units to each other, the transmit of one unit must be connected to the receive of the other. Pairs are not polarity sensitive. See Section 5 for connector pinouts.

Cables for connecting the units to the telco demarc and a DSU/CSU or router are available from DCB. See Section 5 for part numbers.

#### NOTE

Cable should be Category 3, 2 twisted pair, shielded. **DO NOT** use Category 5 cable unless absolutely necessary. If Cat 5 cable must be used, use separate bundles for the Tx and Rx pairs.

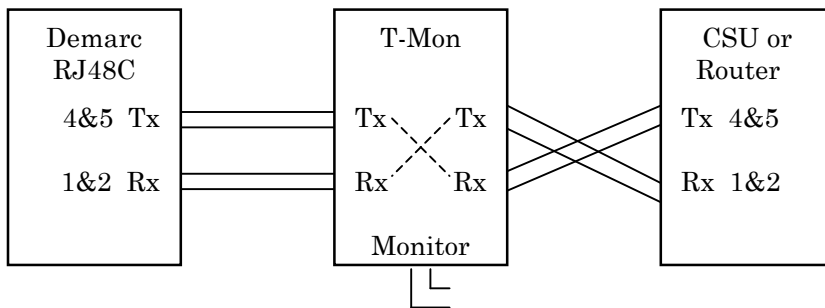

Connections for local monitor.

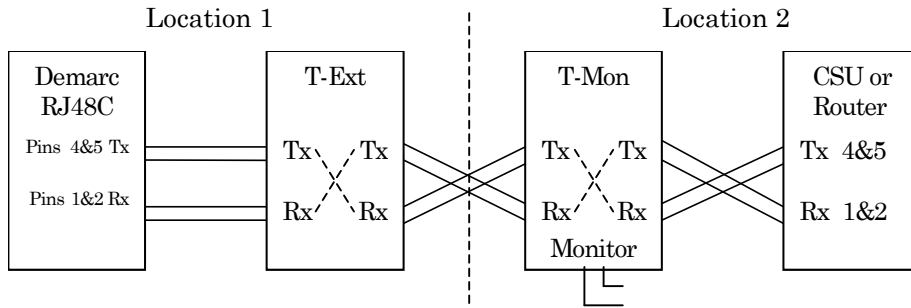

Connections for remote monitor.

The supplied RJ48 adapters allow all of the above connections to be made using straight through wired RJ to RJ cables (patch cords).

For connection to a TELCO Demarc use the adapter labeled “To TELCO Net”, P/N 9502122 (green circuit board).

To make the crossover connection between two T/E-Monitors or between a T/E-Extender and a T/E-Monitor use adapter “To TELCO Net”, P/N 9502122 on one unit and P/N 9502172, “To Cust Equip” (blue circuit board) on the other.

To connect to customer equipment such as a Router, DSU or PBX, use the adapter labeled “To Cust Equip”, P/N 9502172 (blue circuit board).

---

## 4. FRONT PANEL INDICATORS

---

### 4.1 Indicators

<u>Indicator</u>	<u>Condition</u>	<u>Meaning</u>
Power	ON	Power is applied to the unit.

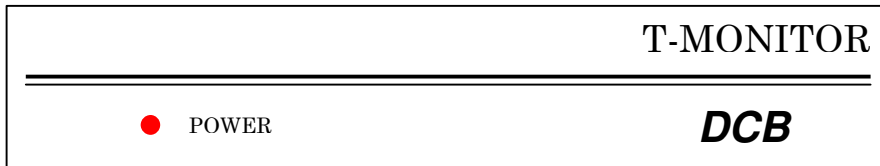

---

## 5. INTERFACE SIGNALS AND CABLES

---

### 5.1 Connector Location and Pin Reference

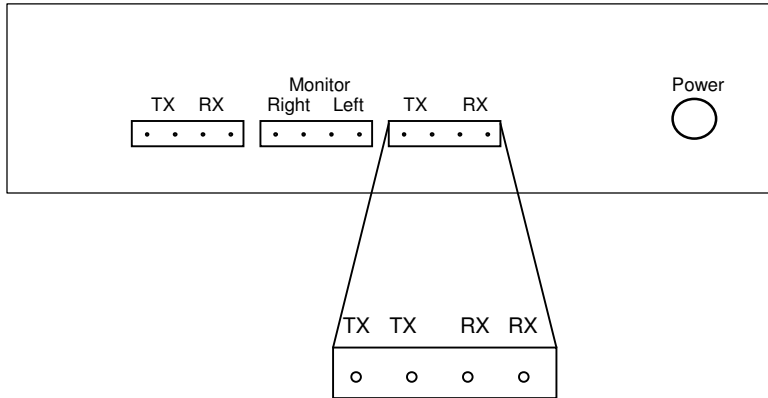

Rear Panel and Connectors

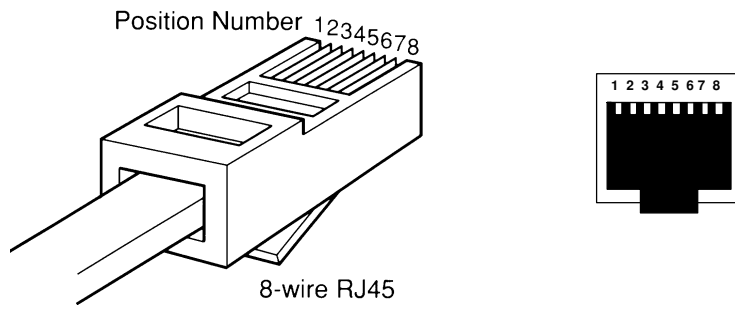

8-wire RJ45

RJ45 Positions



## 5.2 T-1 Interface

### 5.2.1 Terminal Block

<u>Signal</u>	<u>In/Out</u>
Receive	IN
Receive	IN
Transmit	OUT
Transmit	OUT

### 5.2.2 RJ48 Adapter, "To TELCO Net" P/N 9502122 (Green)

<u>Pin</u>	<u>Signal</u>	<u>In/Out</u>
1	Receive	IN
2	Receive	IN
3	not used	
4	Transmit	OUT
5	Transmit	OUT
6	not used	
7	not used	
8	not used	

Use this adapter and a straight through cable to connect to a TELCO Demarc (Network) interface.

### 5.2.3 RJ48 Adapter, "To Cust Equip" P/N 9502172 (Blue)

<u>Pin</u>	<u>Signal</u>	<u>In/Out</u>
1	Receive	OUT
2	Receive	OUT
3	not used	
4	Transmit	IN
5	Transmit	IN
6	not used	
7	not used	
8	not used	

Use this adapter and a straight through cable to connect to an Equipment (DSU, Router, PBX, etc.) interface.

### 5.3 Cables

- 5.3.1 T-Monitor to TELCO Demarc using RJ48 adapter 9502122.  
This cable is available from DCB, P/N 9500095.

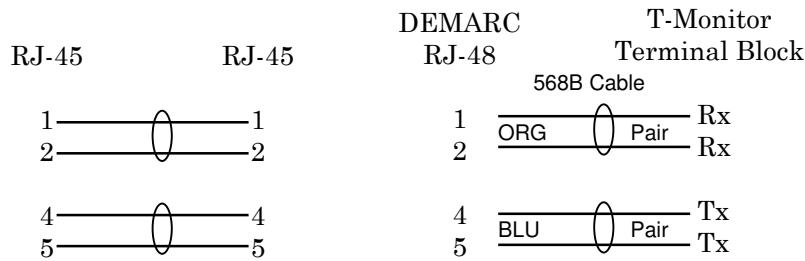

- 5.3.2 T-Monitor to a T-Extender or another T-Monitor using RJ48 adapter 9502122 on both.  
This cable is available from DCB, P/N 9500099.

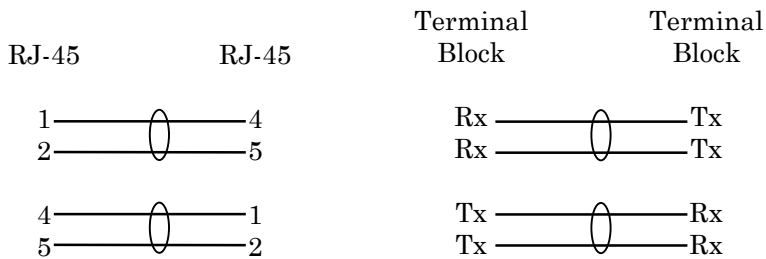

**NOTE**

If one adapter 9502122 and one 9502172 are used then this connection can be made using straight through RJ to RJ wiring.

5.3.3 T-Monitor to a DSU/CSU, PBX or Router with RJ48 interface using RJ48 adapter 9502122.  
 This cable is available from DCB, P/N 9500099.

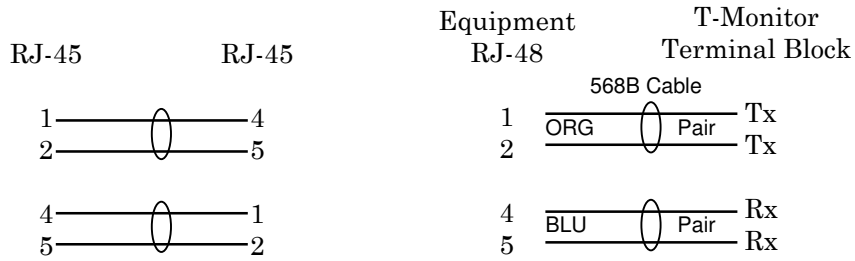

5.3.4 T-Monitor to a DSU/CSU with DA-15 interface

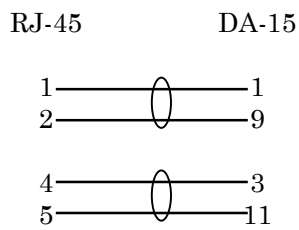

5.3.5 Sources for Individually Shielded Twisted Pair Cable:

- Beldon # 7838A
- Comm Scope # 21102D
- General Cable # 7056880
- Madison Cable # 14035
- Quabbin Wire & Cable # 9770

---

## 6. TROUBLESHOOTING

---

### 6.1 General Approach

When troubleshooting problems, a rational plan can save you many hours of frustration. The following is a brief outline of standard troubleshooting procedures.

1. Gather the facts to determine the exact nature of the problem.
2. Draw a picture of the system showing the equipment at both ends and the in-house wiring. Use this as a reference to note your observations, test steps and test results. A picture keeps you focused and often saves duplicate effort.
3. If you change anything, change only one thing at a time.

### 6.2 Common Problems

The most common problems when installing the T-Monitor are wiring problems. Wiring problems fall into two categories; incorrect cable type and improper connections.

We recommend using only Category 3, two twisted pair, shielded cable. Category 5, 5e, or 6 cable should not be used. If cat. 5 cable must be used, it is recommended that one pair be used from each of two separate cat. 5 cables to minimize cross-talk (NEXT).

When connecting T/E-Monitors be sure that outputs are connected to inputs and inputs are connected to outputs. See diagram on page 4 and interface information in Section 5.

### 6.3 Assistance

If you need assistance troubleshooting your system, contact DCB customer support at (217) 897-6600 between 8:00 am and 5:00 pm central time Monday through Friday.

---

## 7. WARRANTY

---

DCB products are warranted to be free of defects in materials and workmanship for two years. Data Comm for Business, Inc. will repair or replace any equipment proven to be defective within the warranty period. All warranty work is F.O.B. Dewey, IL. This warranty is exclusive of abuse, misuse, accidental damage, acts of God or consequential damages, etc. DCB liability shall not exceed the original purchase price.

All equipment returned for warranty repair must be accompanied by a Returned Material Authorization (RMA) number. To receive an RMA number, call (217) 897-6600 between the hours of 8 AM and 5 PM central time. Equipment must be shipped prepaid to DCB and will be returned at DCB's expense.

Ship returned items to:

Data Comm for Business  
2949 County Road 1000E  
Dewey, IL 61840  
ATTN: your RMA number

Data Comm for Business, Inc.  
PO Box 6329  
Champaign, IL 61826-6329

Tel (217) 897-6600  
Fax (217) 897-1331